



HMR – Linear Drive Driving the future.

aerospace
climate control
electromechanical
filtration
fluid & gas handling
hydraulics
pneumatics
process control
sealing & shielding



ENGINEERING YOUR SUCCESS.

EL Sizing

The dimensioning program for electric linear drives

Download available at www.parker-origa.com

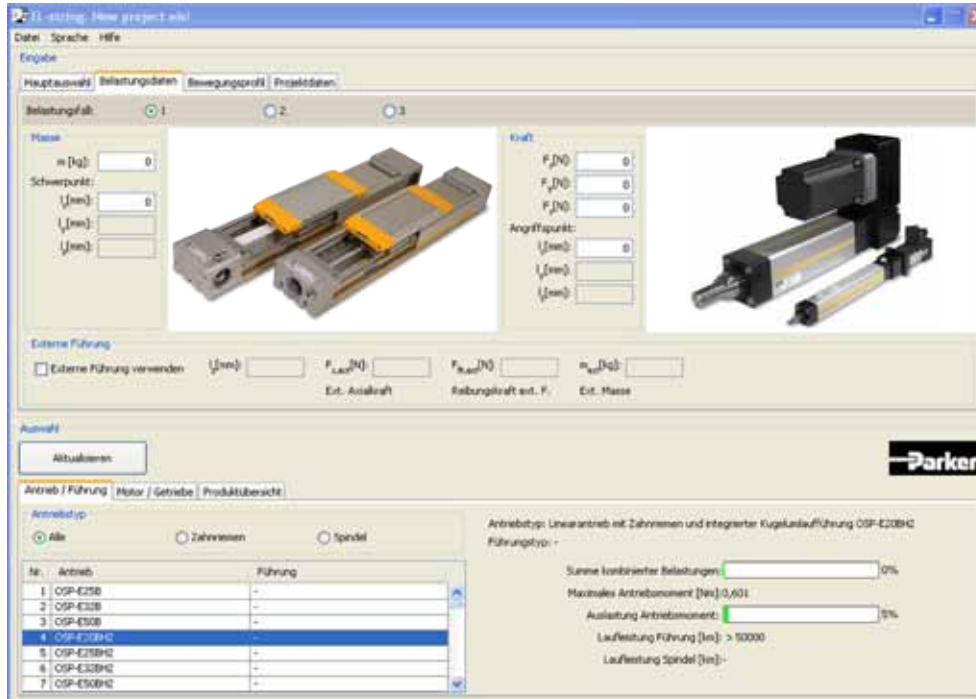

ORIGA Linear Drives

HMR Series

Table of Contents	page
Profile Version	6
- Loads forces and bending moments	7
Ball Screw	11
- Drive Data	12
- Performance / Thrust Force	13
- Dimensions	15
- Weight, Mass, Inertia	17
- Order Stroke	18
- Order Code	20
Belt	23
- Drive Data	24
- Thrust Force	25
- Dimensions	26
- Weight, Mass, Inertia	28
- Order Stroke	29
- Order Code	30
Options	33
- Protection Class	34
- Impact Protection	35
- Position Detection	37
Accessories	41
- Coupling Housing	42
- Motor Coupling	43
- Mountings	44
- T-slot Fixture	45
Drive Combinations	46
- Ball Screw Drive	46
- Belt Drive	48

ORIGA HMR Electromechanical Linear Actuators



Profile designs

- Basic profile for assembling directly to the machine base
- Reinforced profile for self-supporting assembly



Mounting systems

- Integrated T-slots for attaching from below and from the side



Protection classes

- Without cover: Standard
- With cover: IP54



Guide systems

- Plain bearing guide
- Recirculating ball bearing guide



Lubrication

- Central lubrication via externally accessible lubricating nipples

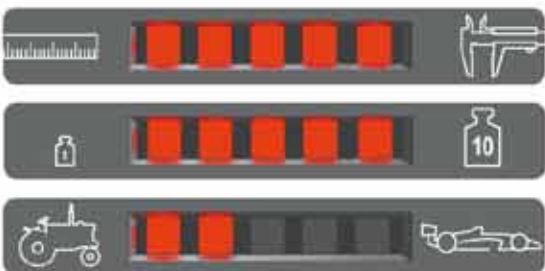
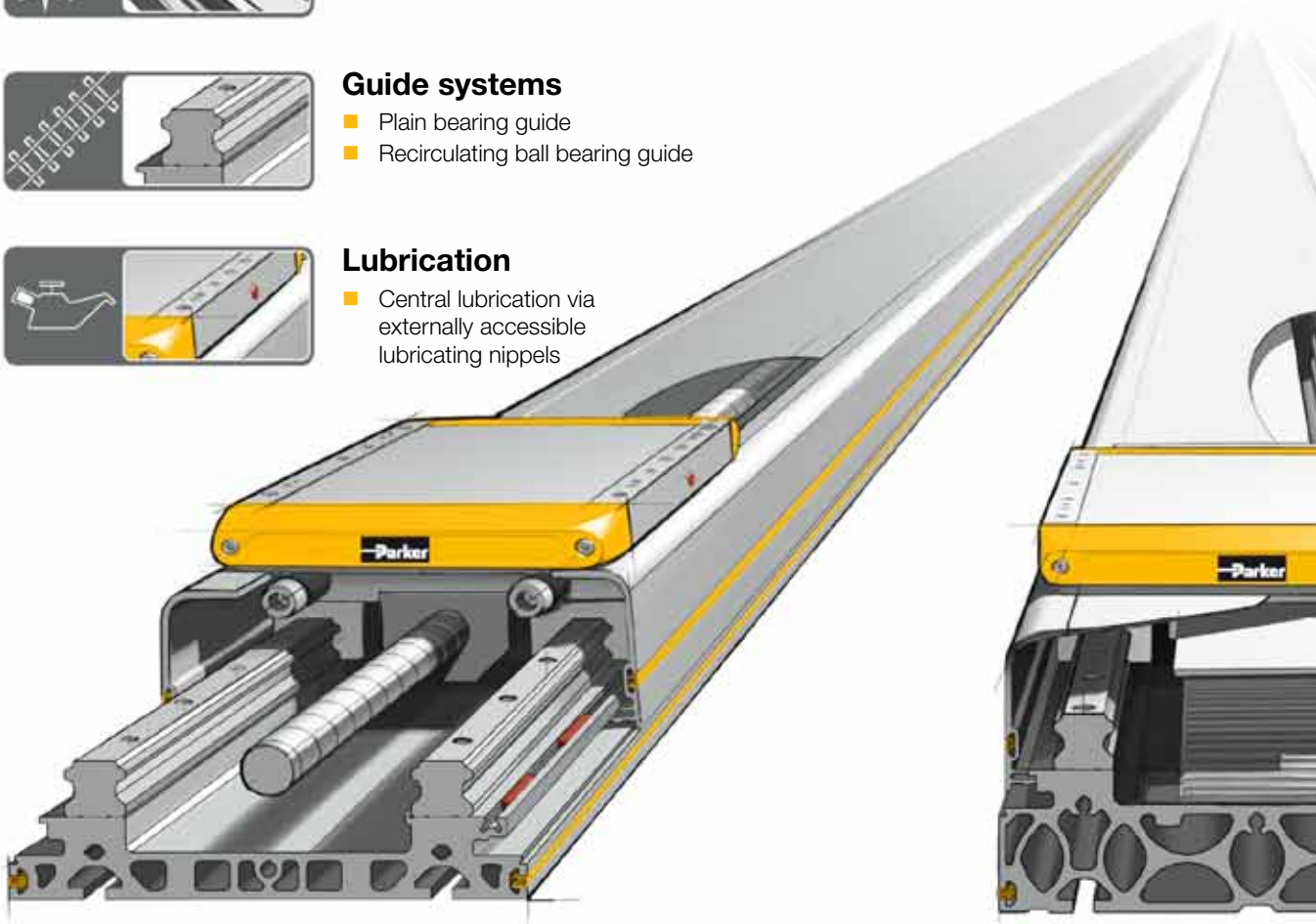

Screw drive

The solution for precise path and position control for heavy loads

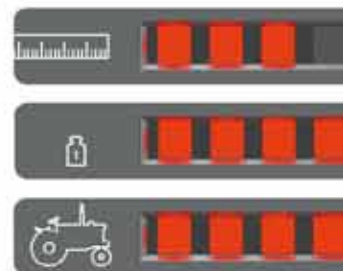

Toothed belt drive

The solution for fast path and position control for medium loads

We drive the future - with screw or toothed belt.

Position sensing

- Integrated, adjustable position switch for end positions and homing

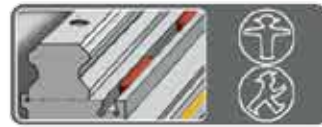

Impact protection

- Integrated shock absorbers for both end positions



Distance measurement

- Contact-free, incremental displacement measuring system



Brake system

- Holding brake can be implemented for horizontal and vertical movements



Cable drag chains

- Directly attachable drag chains for various cabling

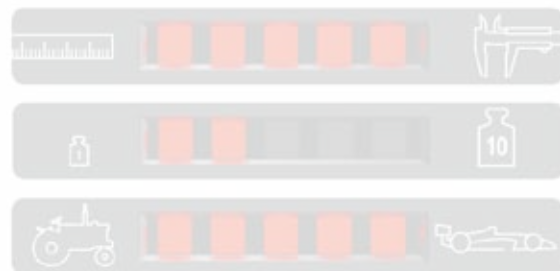
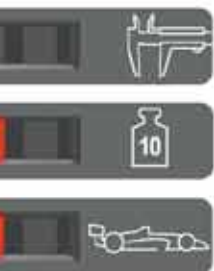
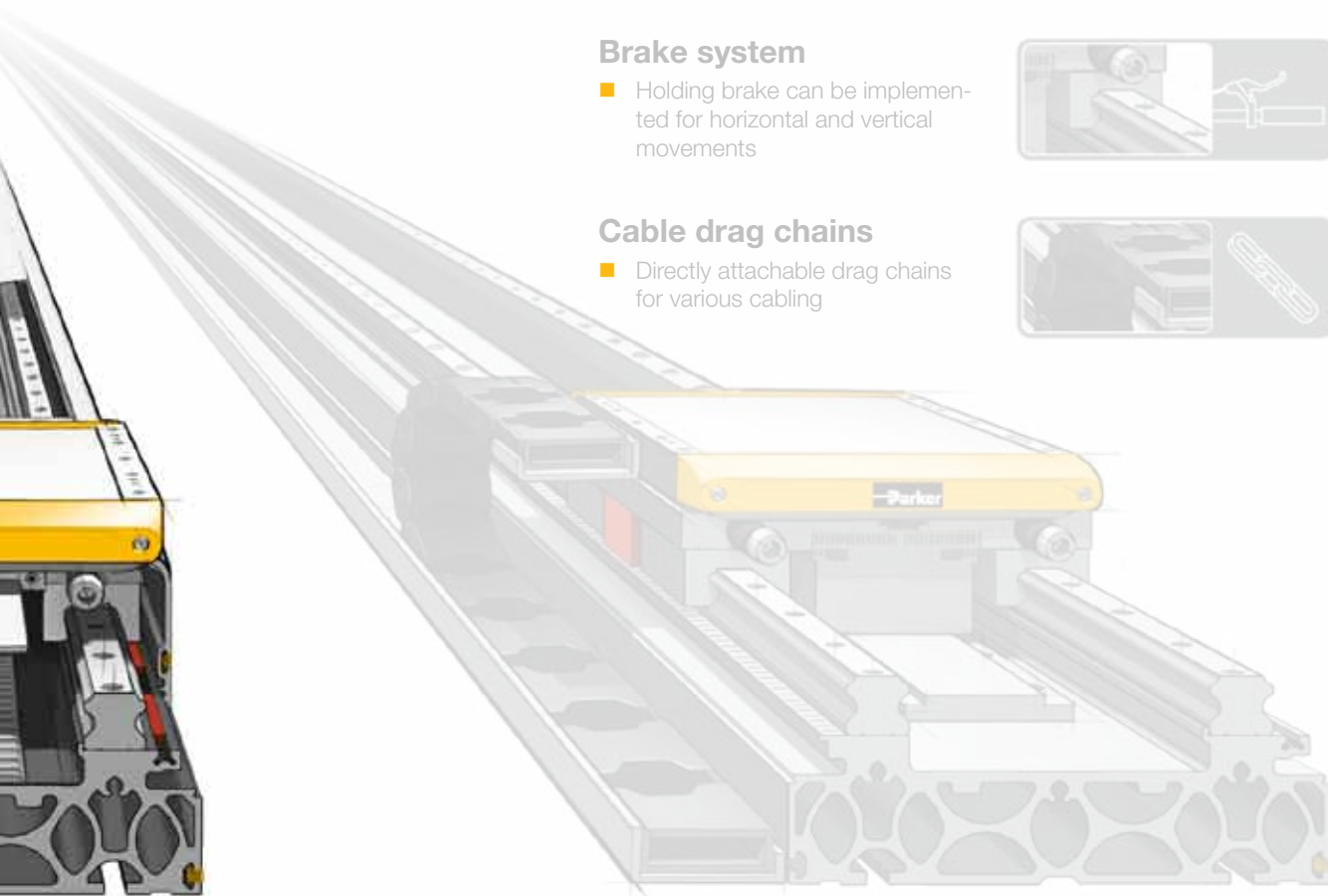

Linear drive (under work)

The solution for fast travel with the greatest possible dynamics and precision

oads

ORIGA Linear Drives

HMR Series

Profile Versions

Sizes 85, 110, 150, 180, 240 mm

Designs

- Basic

- Reinforced

The HMR linear drive system can be equipped with a “basic” or “reinforced” profile as standard. The “basic” profile is suitable for fitting directly to a machine base that has a corresponding support surface. The “reinforced” profile, on the other hand, is the preferred choice for self-supporting systems or for use in conjunction with a base surface offering limited support. The permissible temperature range for both profile versions is -20°C ... +80°C.

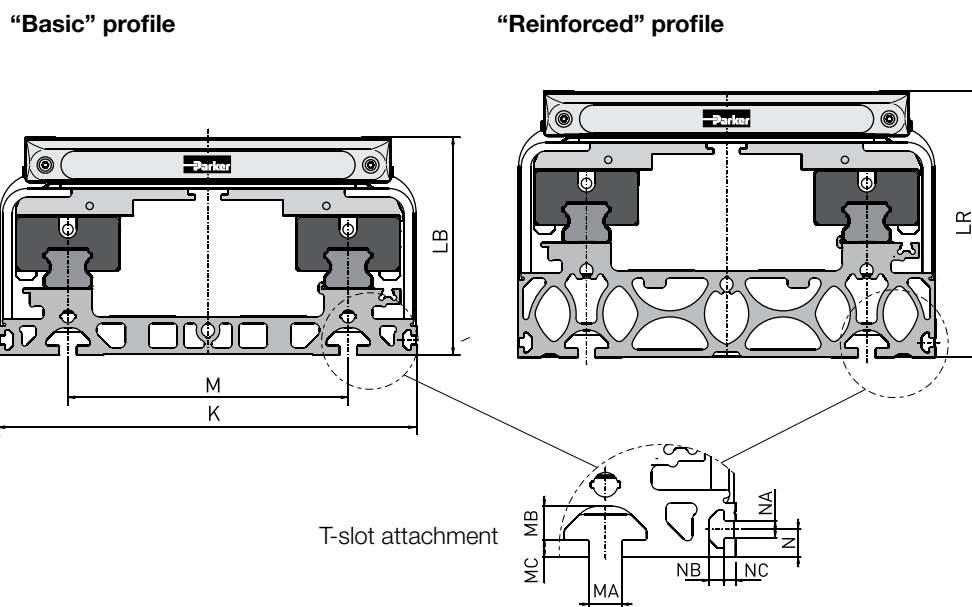

Dimensions - Profil design HMR

Product Size		K	LB	LR	M	MA	MB	MC	N	NA	NB	NC
HMRx085	[mm]	85.0	60.0	71.0	50.0	5.2	4.5	1.5	4.5	3.4	3.0	2.5
HMRx110	[mm]	110.0	69.5	89.5	70.0	5.2	4.5	1.8	4.5	3.4	3.0	2.5
HMRx150	[mm]	150.0	90.0	114.0	96.0	6.2	6.8	3.0	6.5	5.2	4.6	3.5
HMRx180	[mm]	180.0	111.5	134.5	116.0	8.0	7.8	4.5	8.5	5.2	4.5	3.5
HMRx240	[mm]	240.0	125.0	153.0	161.0	10.0	10.2	5.3	8.5	5.2	4.5	3.5

ORIGA Linear Drives

HMR Series

Profile version „reinforced“

Sizes 85, 110, 150, 180, 240 mm

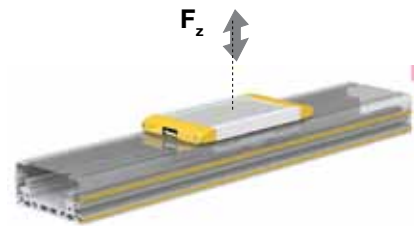

Max. admissible loads [N] and supporting distances [mm] (self-supporting)

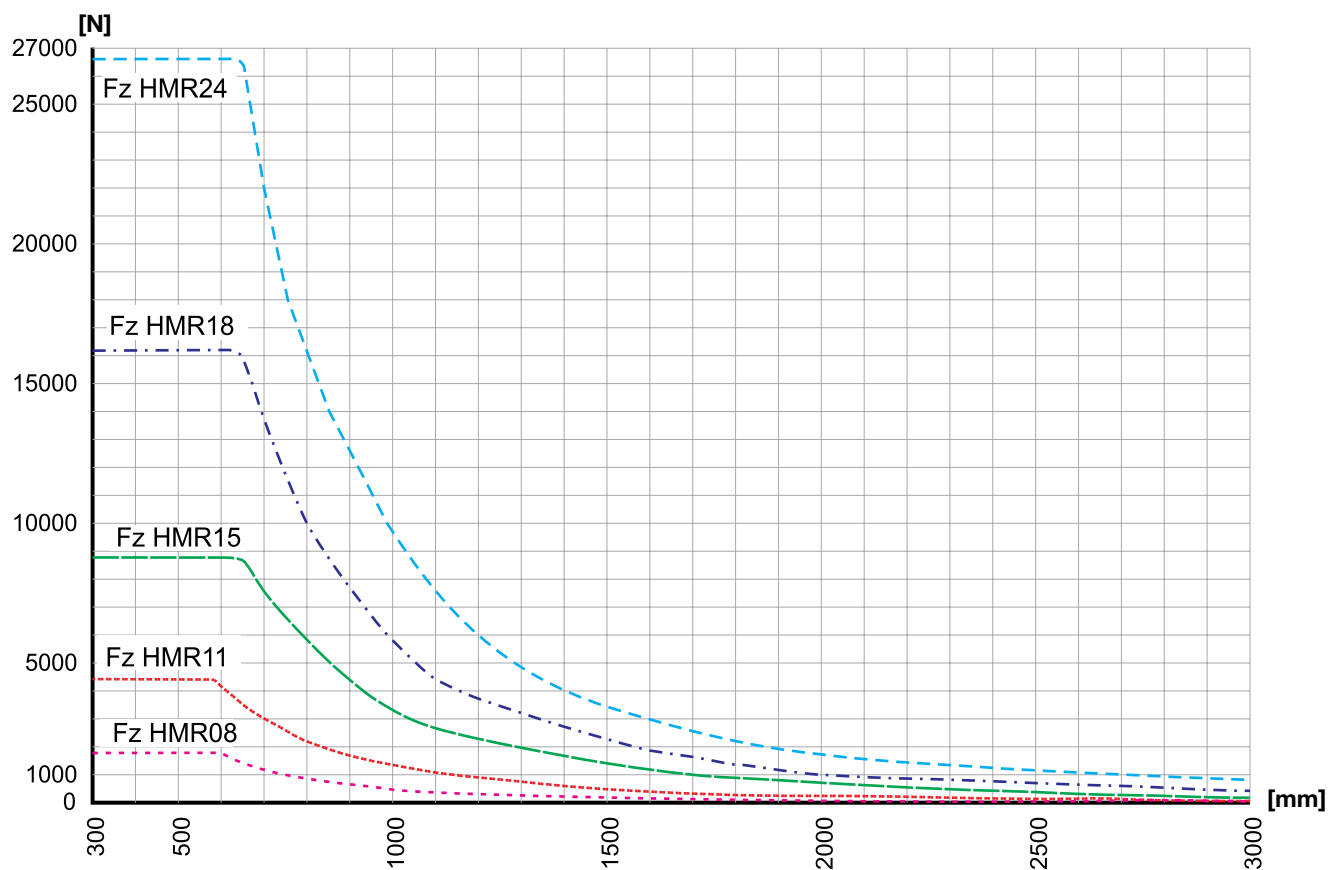

Example F_z HMR 11:

For a 2.800 N load the distance „D“ between supporting elements is 720 mm.
Mounting accessories see „Accessories / T-Slot Mounting“

ORIGA Linear Drives

HMR series

Profile version „reinforced“

Sizes 85, 110, 150, 180, 240 mm

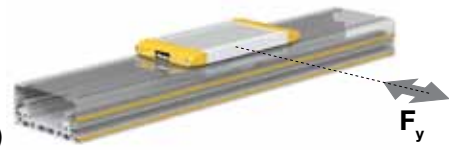

Max. admissible loads [N] and supporting distances [mm] (self-supporting)

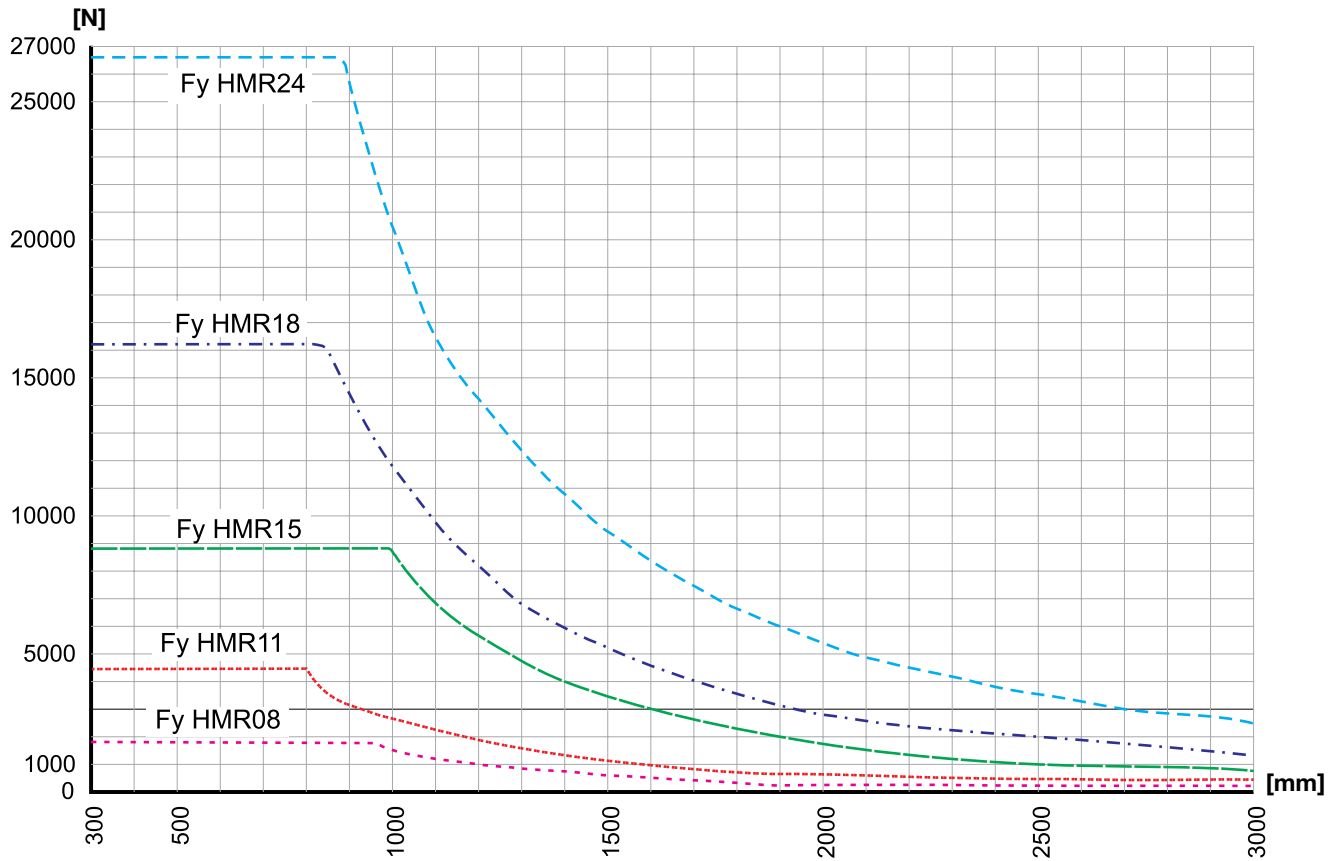

Example F_y HMR 11:

For a 3.160 N load the distance „D“ between supporting elements is 900 mm.
Mounting accessories see „Accessories / T-Slot Mounting“

ORIGA Linear Drives

HMR series

Ball bearing guide

Sizes 85, 110, 150, 180, 240 mm

Load requirements for guides and installation size.

The occurring loads, forces and bending moments depend on the application. The mass of the construction attached to the carriage has a center of gravity. This mass creates static forces ($F = m \cdot g$) and bending moments ($M = m \cdot g \cdot l$). Additional dynamic moments ($M = m \cdot a \cdot l$) arise in dependence of the acceleration during travel. Care should be taken when selecting suitable guides that the permissible sum of loads does not exceed 1.

Loads, forces and bending moments

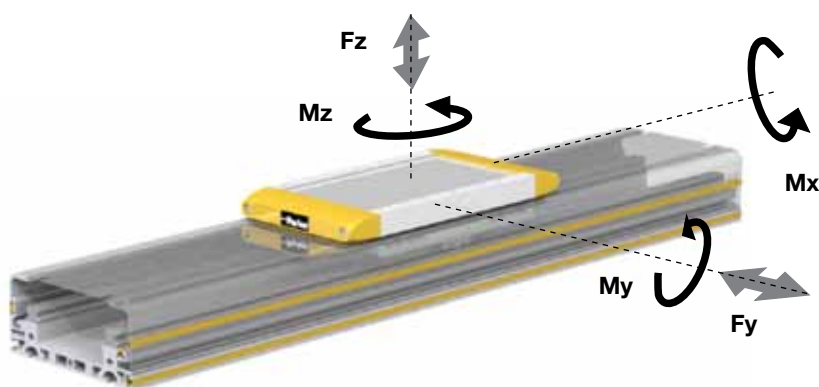

Internal lever arm l_{zi}

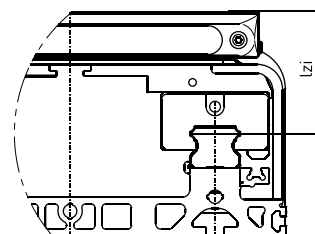

Dimensions - Internal lever arm l_{zi}

Product size	[mm]	l_{zi}
HMRx085	[mm]	33.0
HMRx110	[mm]	39.5
HMRx150	[mm]	50.0
HMRx180	[mm]	57.5
HMRx240	[mm]	68.0

Combined loads

The maximum permissible load for linear drives subject to simultaneous multiple

loads, forces and bending moments are calculated using the formula below.

$$L = \frac{F_y}{F_{y(max)}} + \frac{F_z}{F_{z(max)}} + \frac{M_x}{M_{x(max)}} + \frac{M_y}{M_{y(max)}} + \frac{M_z}{M_{z(max)}} \leq 1$$

Maximum permissible loads must not be exceeded.

The sum of all loads must under no circumstance be > 1.

Maximum permissible loads based on a performance of 2,540 km

Product Size		HMRx08	HMRx11	HMRx15	HMRx18	HMRx24	HMRx08	HMRx11	HMRx15	HMRx18	HMRx24
Carriage		Standard					Tandem				
Max. permissible load											
F_{z2540} F_{y2540}	[N]	1,800	4,450	8,800	16,200	26,600	2,700	6,700	13,200	24,300	39,900
Max. permissible bending moment											
M_{x2540}	[Nm]	45	155	430	940	2,150	68	235	645	1,410	3,225
M_{y2540} M_{z2540}	[Nm]	80	200	560	1,230	2,430	120	300	840	1,845	3,645

Maximum permissible loads based on a performance of 8,000 km

Product Size		HMRx08	HMRx11	HMRx15	HMRx18	HMRx24	HMRx08	HMRx11	HMRx15	HMRx18	HMRx24
Carriage		Standard					Tandem				
Max. permissible load											
F_{z8000} F_{y8000}	[N]	1,250	3,000	6,000	11,000	18,200	1,875	4,500	9,000	16,500	27,300
Max. permissible bending moment											
M_{x8000}	[Nm]	30	105	290	640	1,460	45	160	435	960	2,190
M_{y8000} M_{z8000}	[Nm]	55	135	380	840	1,660	80	205	570	1,260	2,490

HMRS Ball Screw



ORIGA Linear Drives

Series HMRS / Ball Screw / Drive Data / Sizes 85, 110, 150, 180, 240 mm

Technical Data HMRS

Product Size			HMRS08		HMRS11		HMRS15		HMRS18		HMRS24	
Type of Screw			12 x 5	12 x 12	16 x 5	16 x 16	20 x 5	20 x 20	25 x 10	25 x 25	32 x 10	32 x 32
Pitch	p	[mm]	5	12	5	16	5	20	10	25	10	32
Max. speed	v _{max.}	[m/s]	0.25	0.60	0.25	0.80	0.25	1.00	0.50	1.25	0.50	1.60
Max. acceleration	a _{max.}	[m/s ²]	10		10		10		10		10	
Repeatability		[μm]	± 20		± 20		± 20		± 20		± 20	
Max. stroke		[mm]	1,200		1,500		2,500		3,400		4,000	
Thrust force and torque												
Max. thrust force	F _{Amax}	[N]	820	820	2,200	2,200	2,600	2,600	4,800	4,800	5,500	5,500
	F _{A2540}	[N]	820	650	1,550	1,150	1,800	2,160	3,300	3,960	3,500	4,880
Max. torque at drive shaft	M _{Amax}	[Nm]	0.7	1.7	1.9	6.1	2.2	9.0	8.3	20.8	9.5	30.4
	M _{A2540}	[Nm]	0.7	1.3	1.3	3.1	1.6	7.5	5.7	17.1	6.1	27.0
No load torque	M ₀	[Nm]	0.2	0.2	0.3	0.4	0.7	0.9	0.9	1.0	1.0	1.1
Stroke dependent speed												
Max. permissible speed at order stroke	200	[mm]	250	600	250	800	250	1,000	500	1,250	500	1,600
	400	[mm]	250	600	250	800	250	1,000	500	1,250	500	1,600
	600	[mm]	152	366	197	631	250	1,000	500	1,250	500	1,600
	800	[mm]	102	245	132	424	169	678	382	956	423	1,354
	1000	[mm]	73	176	95	304	122	486	277	694	312	997
	1200	[mm]	55	132	71	228	91	366	211	526	239	765
	1400	[mm]	-	-	56	178	71	285	165	413	189	605
	1600	[mm]	-	-	45	143	57	228	133	333	153	491
	1800	[mm]	-	-	-	-	47	187	109	274	127	406
	2000	[mm]	-	-	-	-	39	156	92	229	107	342
	2200	[mm]	-	-	-	-	33	132	78	195	91	291
	2400	[mm]	-	-	-	-	28	113	67	167	79	251
	2600	[mm]	-	-	-	-	-	-	58	145	68	219
	2800	[mm]	-	-	-	-	-	-	51	128	60	193
	3000	[mm]	-	-	-	-	-	-	45	113	53	171
	3200	[mm]	-	-	-	-	-	-	40	100	48	152
	3400	[mm]	-	-	-	-	-	-	-	-	43	137
3600	[mm]	-	-	-	-	-	-	-	-	39	123	
3800	[mm]	-	-	-	-	-	-	-	-	35	112	
4000	[mm]	-	-	-	-	-	-	-	-	32	102	



ORIGA Linear Drives

Series HMRS / Ball Screw / Performance / Thrust Force Sizes 85, 110, 150, 180, 240 mm

Performance expectancy depends on the application's required force. An increase in force will reduce performance.

HMRS08 Performance / Thrust force

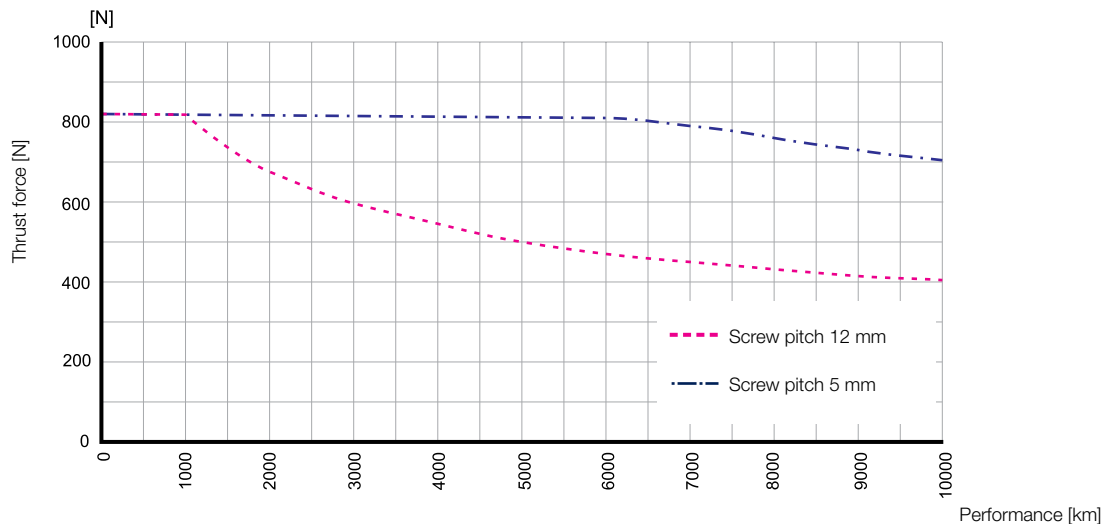

HMRS11 Performance / Thrust force

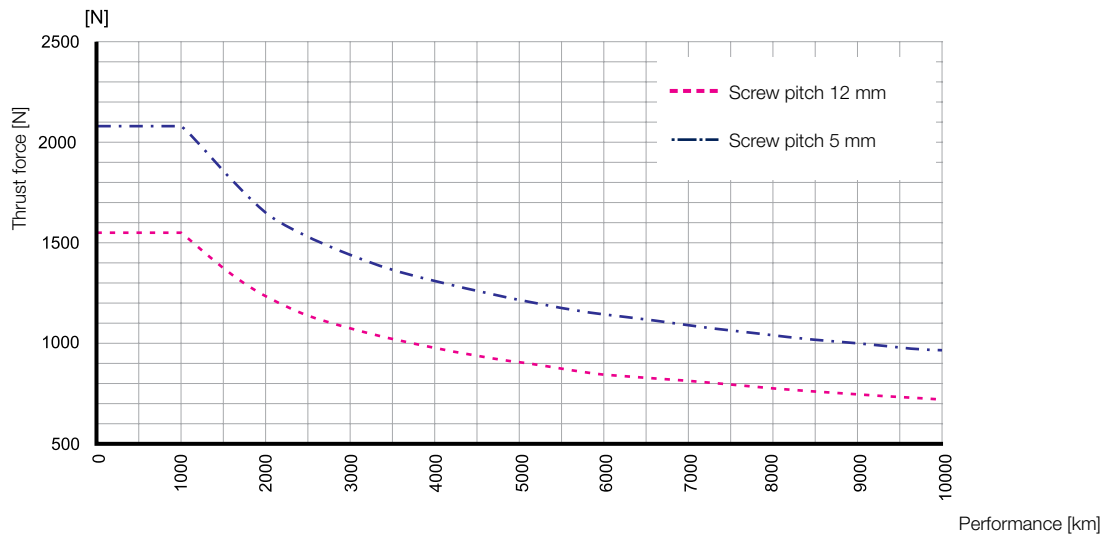

HMRS15 Performance / Thrust force

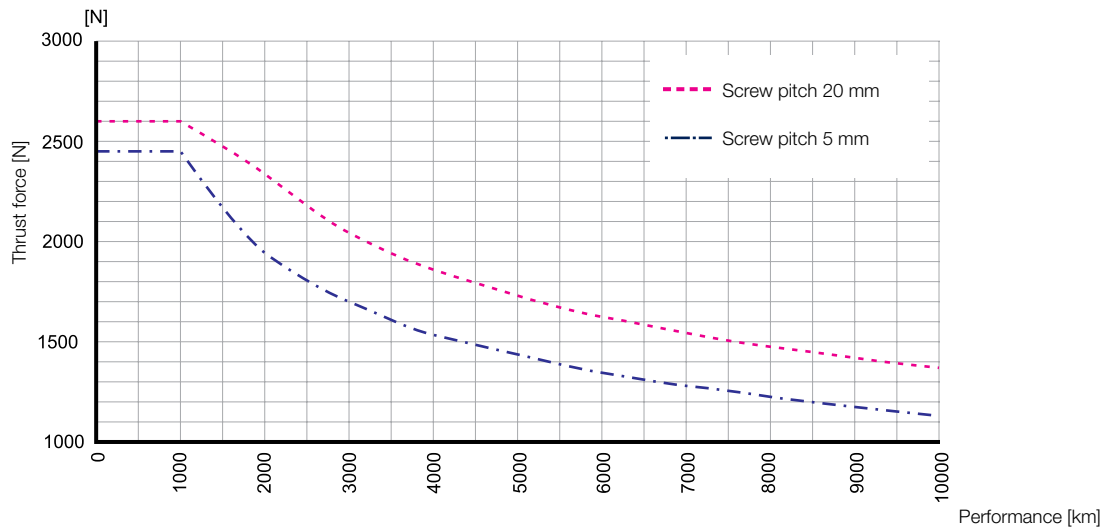

HMRS18 Performance / Thrust force

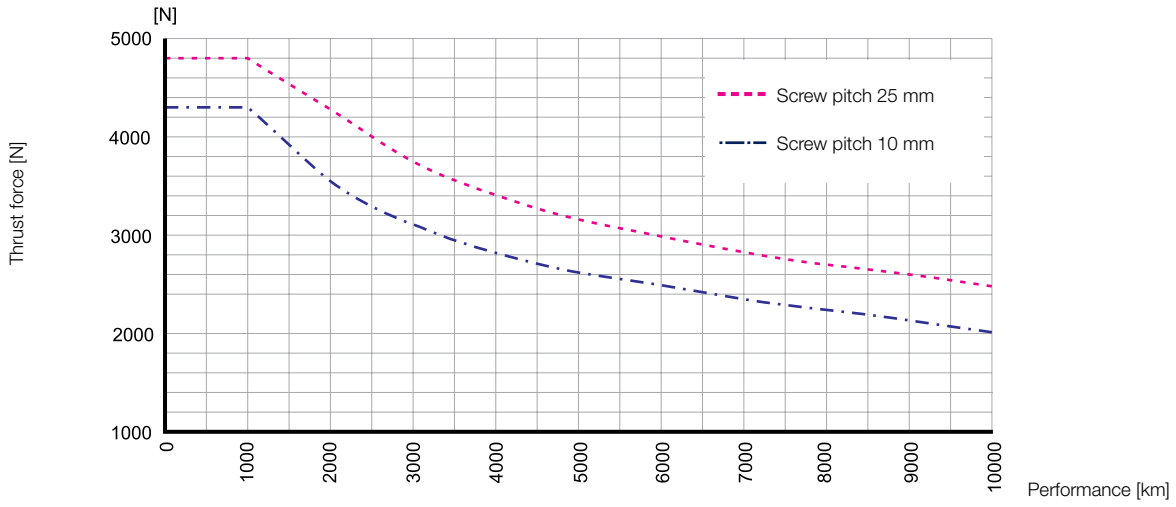

HMRS24 Performance / Thrust force

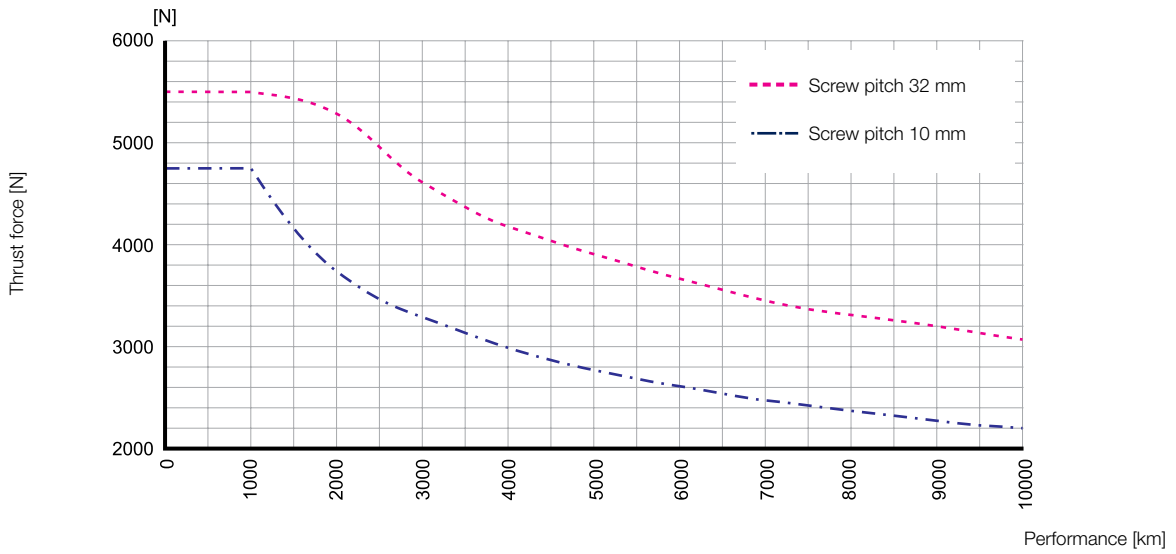

ORIGA Linear Drives

Series HMRS / Ball screw / Dimensions / Sizes 85, 110, 150, 180, 240 mm

Basic dimensions

"Basic" profile

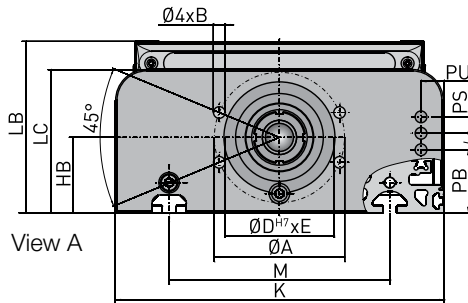

"Reinforced" profile

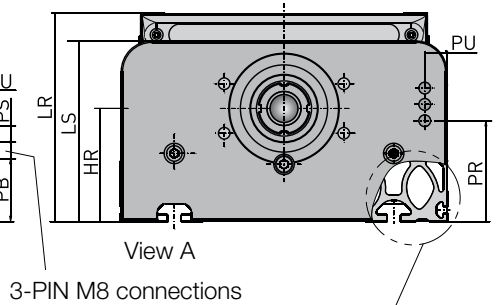

3-PIN M8 connections

T-slot attachment

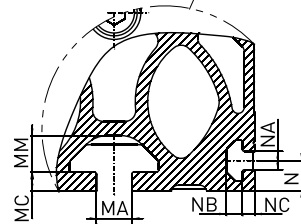

A ▶

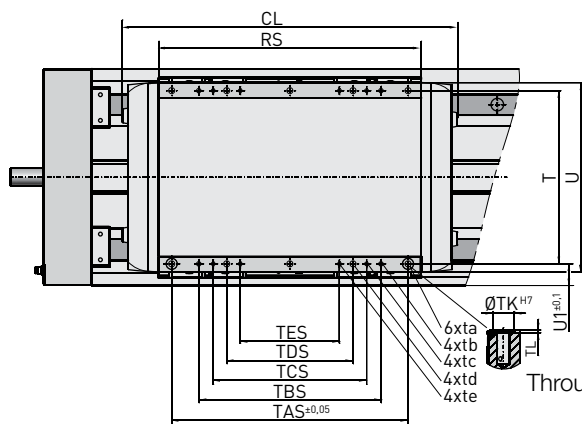
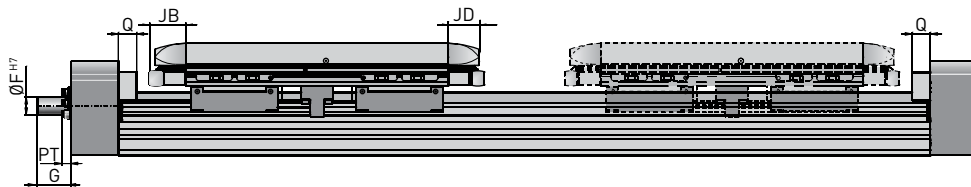

Carriage dimensions

Through-hole attachment

ORIGA Linear Drives

Series HMRS / Ball screw / Dimensions / Sizes 85, 110, 150, 180, 240 mm

Dimension table - HMRS

Prod.size	ØA	B	ØD ^{H7}	E	ØF ^{H7}	G	HB	HR	K	LB	LC	LR	LS
HMRS08 [mm]	42.0	M4	34.0	3.0	6.0	11.0	26.0	37.0	85.0	60.0	52.5	71.0	63.5
HMRS11 [mm]	51.0	M6	39.0	5.0	10.0	18.0	32.0	52.0	110.0	69.5	60.5	89.5	80.5
HMRS15 [mm]	72.0	M8	54.0	4.0	12.0	31.0	36.0	60.0	150.0	90.0	74.0	114.0	98.0
HMRS18 [mm]	80.0	M8	64.0	2.5	15.0	33.0	44.0	67.5	180.0	111.5	93.5	134.5	116.5
HMRS24 [mm]	95.0	M10	80.0	2.5	20.0	37.0	55.0	83.0	240.0	125.0	104.5	153.0	132.5

Dimension table - HMRS

Prod.size	M	MA	MB	MC	N	NA	NB	NC	PB	PR	PS	PT	PU	Q
HMRS08 [mm]	50.0	5.2	4.5	1.5	4.5	3.4	3.0	2.5	19.3	30.3	12.0	9.0	7.1	16.0
HMRS11 [mm]	70.0	5.2	4.5	1.8	4.5	3.4	3.0	2.5	23.5	43.5	12.0	9.0	8.5	20.0
HMRS15 [mm]	96.0	6.2	6.8	3.0	6.5	5.2	4.6	3.5	15.0	39.0	12.0	9.0	15.0	20.0
HMRS18 [mm]	116.0	8.0	7.8	4.5	8.5	5.2	4.5	3.5	28.0	51.0	12.0	9.0	18.0	20.0
HMRS24 [mm]	161.0	10.0	10.2	5.3	8.5	5.2	4.5	3.5	46.0	74.0	12.0	9.0	16.5	20.0

Dimension table - carriage standard HMRS

Prod.size	JB	JD	CL	RS	T	TAS	ta	TBS	tb	TCS	tc	TDS	td	TES
HMRS08 [mm]	33.5	30.0	195.0	128.0	74.0	97.0	M4x12	70.0	M4x12	40.0	M4x12	-	-	-
HMRS11 [mm]	37.5	34.0	225.0	150.0	96.0	122.0	M5x12	97.0	M5x12	65.0	M5x12	25.0	M5x12	-
HMRS15 [mm]	37.5	34.0	266.0	191.0	120.0	170.0	M5x12	122.0	M5x12	-	-	70.0	M5x12	-
HMRS18 [mm]	40.0	34.0	311.0	231.0	150.0	202.0	M6x12	170.0	M5x10	122.0	M5x10	90.0	M6x12	-
HMRS24 [mm]	40.0	34.0	371.0	291.0	192.0	262.0	M8x16	202.0	M6x12	170.0	M5x10	140.0	M8x16	122.0

Dimension table - carriage standard HMRS

Prod.size	te	ØTKH7	TL	U	U1
HMRS08 [mm]	-	7.0	1.5	83.0	5.5
HMRS11 [mm]	-	7.0	1.5	105.0	7.0
HMRS15 [mm]	-	7.0	1.5	135.0	15.0
HMRS18 [mm]	-	9.0	1.5	165.0	15.0
HMRS24 [mm]	M5x10	12.0	1.5	210.0	24.0

ORIGA Linear Drives

Series HMRS / Weight, mass and inertia

Weight and mass HMRS

Product size			HMRS08				HMRS11				HMRS15			
Weight of actuator														
Version of actuator (see order code)			B	C	R	S	B	C	R	S	B	C	R	S
Weight actuator. 0 - order stroke	m_0	[kg]	1.8	2.1	2.2	2.5	3.5	3.9	4.6	5.0	5.2	6.1	7.1	7.9
Weight actuator per 1 meter	m_{mt}	[kg/m]	3.7	4.7	4.8	5.7	6.6	7.6	8.8	9.9	12.1	13.9	15.5	17.2
Moving mass														
Version of carriage (see order code)			0		1		0		1		0		1	
Weight actuator	m_c	[kg]	1.0		0.7		1.6		1.3		2.6		1.8	

Weight and mass HMRS

Product size			HMRS18				HMRS24			
Weight of actuator										
Version of actuator (see order code)			B	C	R	S	B	C	R	S
Weight actuator. 0 - order stroke	m_0	[kg]	8.9	10.0	11.2	12.3	16.5	18.1	20.5	22.2
Weight actuator per 1 meter	m_{mt}	[kg/m]	15.5	17.7	19.1	21.4	25.6	28.3	30.7	33.4
Moving mass										
Version of carriage (see order code)			0		1		0		1	
Weight actuator	m_c	[kg]	4.7		3.7		9.2		7.3	

Total mass HMRS: $m_{tot} = m_0 + m_c + \text{order stroke} * m_{mt}$

Inertia HMRS

Product size			HMRS08		HMRS11		HMRS15	
Pitch (see order code)			5	12	5	16	5	20
Inertia actuator. 0 - order stroke	J_0	[kgmm ²]	4		13		14	
Inertia actuator per 1 meter	J_{mt}	[kgmm ² /m]	14		45		107	
Inertia per 1 kg moving mass	J_{kg}	[kgmm ² /kg]	0.6	3.7	0.6	6.5	0.6	10.1

Inertia HMRS

Product size			HMRS18		HMRS24	
Pitch (see order code)			10	25	10	32
Inertia actuator. 0 - order stroke	J_0	[kgmm ²]	35		96	
Inertia actuator per 1 meter	J_{mt}	[kgmm ² /m]	245		639	
Inertia per 1 kg moving mass	J_{kg}	[kgmm ² /kg]	2.5	15.8	2.5	25.9

Total inertia HMRS: $J_{tot} = J_0 + \text{order stroke} * J_{mt} + m_c * J_{kg} + m * J_{kg}$

ORIGA Linear Drives

Series HMRS / Ball screw / Order stroke / Sizes 85, 110, 150, 180, 240 mm

Order stroke dependent dimensions

- ES = Effective Stroke
- SS = Safety Stroke
- CD = Carriage distance
- CL = Carriage length Standard
- S = Stroke
- OS = Order Stroke
- OAL = Over All Length

Standard design with one carriage

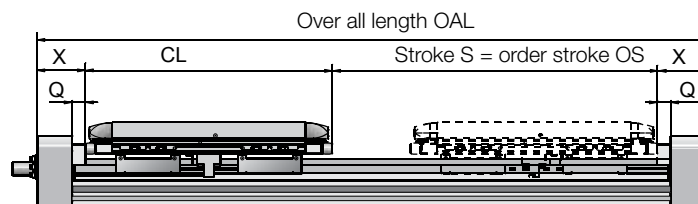

Order stroke OS = Effective stroke ES + 2 x Safety stroke SS
 Over all length OAL = order stroke OS + carrier length CL + 2 x dimension end cap X

Tandem design with two carriages

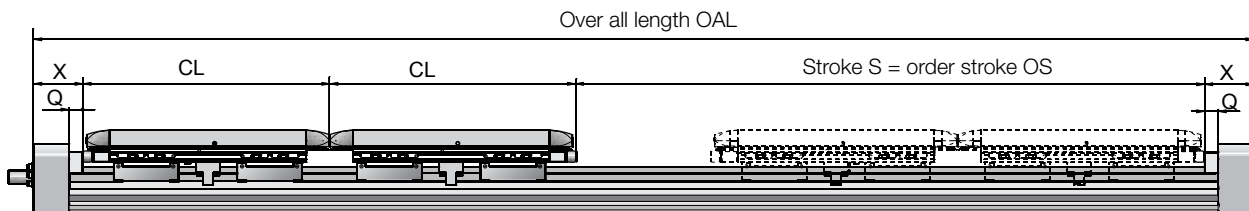

Order stroke OS = Effective stroke ES + 2 x Safety stroke SS + Carrier distance CD (not shown)
 Over all length OAL = Order stroke OS + 2 x carrier length CL + 2 x dimension end cap X

Dimensions - Carriage and end cap HMRS

Product size		CL	Q	X
HMRS08	[mm]	195.0	16.0	54.0
HMRS11	[mm]	225.0	20.0	65.0
HMRS15	[mm]	266.0	20.0	62.0
HMRS18	[mm]	311.0	20.0	66.0
HMRS24	[mm]	371.0	20.0	73.0



ORIGA Linear Drives

Series HMRS

Order code

HMR S 15 B 05 0 - 0000 - 0 0 0 0 0 00 00

Type of actuator

S Ball screw drive

Product size

08	Product width 085 mm
11	Product width 110 mm
15	Product width 150 mm
18	Product width 180 mm
24	Product width 240 mm

Actuator design

B	Basic Profile with ball bearing guide Standard
C	Basic Profile with ball bearing guide and IP54 with outer cover
R	Reinforced Profile with ball bearing guide Standard
S	Reinforced Profile with ball bearing guide and IP54 with outer cover

Pitch

Product size HMRS	08	11	15	18	24
05 Pitch 5 mm with plane drive shaft	<input checked="" type="checkbox"/>	<input checked="" type="checkbox"/>	<input checked="" type="checkbox"/>		
10 Pitch 10 mm with plane drive shaft				<input checked="" type="checkbox"/>	<input checked="" type="checkbox"/>
12 Pitch 12 mm with plane drive shaft	<input checked="" type="checkbox"/>				
16 Pitch 16 mm with plane drive shaft		<input checked="" type="checkbox"/>			
20 Pitch 20 mm with plane drive shaft			<input checked="" type="checkbox"/>		
25 Pitch 25 mm with plane drive shaft				<input checked="" type="checkbox"/>	
32 Pitch 32 mm with plane drive shaft					<input checked="" type="checkbox"/>

Carriage

0	Standard
1	Tandem

Order stroke

0000 4 digits input in mm

Home sensor (one switch)

0	Without
1	R2NO-I: Reed, 2 wire, NO, internal
A	P3NO-I: PNP, 3 wire, NO, internal
K	N3NO-I: NPN, 3 wire, NO, internal
3	R2NO-P: Reed, 2 wire, NO, M8 plug, 0.3 m cable, external
C	P3NO-P: PNP, 3-wire, NO, M8 plug, 0.3 m cable, external
M	N3NO-P: NPN, 3-wire, NO, M8 plug, 0.3 m cable, external
5	R2NO-FL3: Reed, 2 wire, NO, flying leads, 3 m cable, external
E	P3NO-FL3: PNP, 3 wire, NO, flying leads, 3 m cable, external
P	N3NO-FL3: NPN, 3 wire, NO, flying leads, 3 m cable, external
7	R2NO-FL10: Reed, 2 wire, NO, flying leads, 10 m cable, external
G	P3NO-FL10: PNP, 3 wire, NO, flying leads, 10 m cable, external
R	N3NO-FL10: NPN, 3 wire, NO, flying leads, 10 m cable, external

Limit sensor (one switch per end position)

0	Without
2	R2NC-I: Reed, 2 wire, NC, internal
B	P3NC-I: PNP, 3 wire, NC, internal
L	N3NC-I: NPN, 3 wire, NC, internal
4	R2NC-P: Reed, 2 wire, NC, M8 plug, 0.3 m cable, external
D	P3NC-P: PNP, 3 wire, NC, M8 plug, 0.3 m cable, external
N	P3NC-P: PNP, 3 wire, NC, M8 plug, 0.3 m cable, external
6	R2NC-FL3: Reed, 2 wire, NC, flying leads, 3 m cable, external
F	P3NC-FL3: PNP, 3 wire, NC, flying leads, 3 m cable, external
Q	N3NC-FL3: NPN, 3 wire, NC, flying leads, 3 m cable, external
8	R2NC-FL10: Reed, 2 wire, NC, flying leads, 10 m cable, external
H	P3NC-FL10: PNP, 3 wire, NC, flying leads, 10 m cable, external
S	N3NC-FL10: NPN, 3 wire, NC, flying leads, 10 m cable, external



Mounting kits*

Product size HMRS		08	11	15	18	24							
00	Without mounting kit or motor mounting	<input checked="" type="checkbox"/>	<input checked="" type="checkbox"/>	<input checked="" type="checkbox"/>	<input checked="" type="checkbox"/>	<input checked="" type="checkbox"/>							
Gear mounting kit													
A7	PS60			<input checked="" type="checkbox"/>	<input checked="" type="checkbox"/>								
A8	PS90				<input checked="" type="checkbox"/>								
A9	PS115					<input checked="" type="checkbox"/>							
C0	LP050	<input checked="" type="checkbox"/>	<input checked="" type="checkbox"/>										
C1	PV60-TA / LP070		<input checked="" type="checkbox"/>	<input checked="" type="checkbox"/>	<input checked="" type="checkbox"/>								
C2	PV90-TA / LP090				<input checked="" type="checkbox"/>								
C3	PV115-TA / LP120					<input checked="" type="checkbox"/>							
Mounting kit motor													
Size gear mounting		08	11	15	18	24	Ax	Bx	Cx	Dx	Fx	Gx	Hx
A2	SMx60 8/11, MH56 5/11, NX2	<input checked="" type="checkbox"/>	<input checked="" type="checkbox"/>	<input checked="" type="checkbox"/>			<input checked="" type="checkbox"/>	<input checked="" type="checkbox"/>			<input checked="" type="checkbox"/>		
A3	SMx82 8/14		<input checked="" type="checkbox"/>	<input checked="" type="checkbox"/>	<input checked="" type="checkbox"/>			<input checked="" type="checkbox"/>	<input checked="" type="checkbox"/>		<input checked="" type="checkbox"/>	<input checked="" type="checkbox"/>	<input checked="" type="checkbox"/>
A4	SMx100 5/19, MH105 5/19			<input checked="" type="checkbox"/>	<input checked="" type="checkbox"/>	<input checked="" type="checkbox"/>			<input checked="" type="checkbox"/>	<input checked="" type="checkbox"/>		<input checked="" type="checkbox"/>	<input checked="" type="checkbox"/>
A5	SMx115 5/24, SMx142 5/24, MH145 5/24				<input checked="" type="checkbox"/>	<input checked="" type="checkbox"/>			<input checked="" type="checkbox"/>	<input checked="" type="checkbox"/>			<input checked="" type="checkbox"/>
AG	SMx60 5/11, MH70 5/11, NX3	<input checked="" type="checkbox"/>	<input checked="" type="checkbox"/>				<input checked="" type="checkbox"/>	<input checked="" type="checkbox"/>			<input checked="" type="checkbox"/>		
AL	MPP092				<input checked="" type="checkbox"/>			<input checked="" type="checkbox"/>	<input checked="" type="checkbox"/>				
AK	AK - SMx115 7/24, MH105 9/24, NX6								<input checked="" type="checkbox"/>	<input checked="" type="checkbox"/>			<input checked="" type="checkbox"/>
AJ	SMx82 8/19, MH105 7/19, NX4								<input checked="" type="checkbox"/>	<input checked="" type="checkbox"/>		<input checked="" type="checkbox"/>	
AH	SMx60 8/9, MH56 5/9	<input checked="" type="checkbox"/>	<input checked="" type="checkbox"/>				<input checked="" type="checkbox"/>	<input checked="" type="checkbox"/>			<input checked="" type="checkbox"/>		
B0	motor mounting kit (75 / M6 / 60 / 3 / 14 / 30)	<input checked="" type="checkbox"/>						<input checked="" type="checkbox"/>	<input checked="" type="checkbox"/>				
B1	motor mounting kit (90 / M5 / 60 / 3 / 11 / 23)	<input checked="" type="checkbox"/>	<input checked="" type="checkbox"/>				<input checked="" type="checkbox"/>	<input checked="" type="checkbox"/>					
B2	motor mounting kit (90 / M5 / 60 / 3 / 14 / 30)	<input checked="" type="checkbox"/>	<input checked="" type="checkbox"/>					<input checked="" type="checkbox"/>	<input checked="" type="checkbox"/>				
B3	motor mounting kit (95 / M6 / 50 / 3 / 14 / 30)	<input checked="" type="checkbox"/>	<input checked="" type="checkbox"/>					<input checked="" type="checkbox"/>	<input checked="" type="checkbox"/>		<input checked="" type="checkbox"/>	<input checked="" type="checkbox"/>	
B4	motor mounting kit (90 / M6 / 70 / 3 / 16 / 40)							<input checked="" type="checkbox"/>	<input checked="" type="checkbox"/>				

* Mounting kit: contains gear housing, motor coupling and flange

Mounting position limit sensor

0	Without sensor
1	10 mm
2	20 mm
3	30 mm
4	40 mm
5	50 mm
6	60 mm
7	70 mm
8	80 mm
9	90 mm
A	100 mm
B	110 mm
C	120 mm
D	130 mm
E	140 mm
F	150 mm
G	160 mm
H	170 mm
J	180 mm
K	190 mm
L	200 mm

Guide mounting**

Product size HMRS		08	11	15	18	24
00	Without	<input checked="" type="checkbox"/>	<input checked="" type="checkbox"/>	<input checked="" type="checkbox"/>	<input checked="" type="checkbox"/>	<input checked="" type="checkbox"/>
A2	LP050 i = 5	<input checked="" type="checkbox"/>	<input checked="" type="checkbox"/>			
A3	LP050 i = 10	<input checked="" type="checkbox"/>	<input checked="" type="checkbox"/>			
B1	LP070 i = 3		<input checked="" type="checkbox"/>	<input checked="" type="checkbox"/>		
B2	LP070 i = 5		<input checked="" type="checkbox"/>	<input checked="" type="checkbox"/>		
B3	LP070 i = 10		<input checked="" type="checkbox"/>	<input checked="" type="checkbox"/>		
C1	LP090 i = 3				<input checked="" type="checkbox"/>	
C2	LP090 i = 5				<input checked="" type="checkbox"/>	
C3	LP090 i = 10				<input checked="" type="checkbox"/>	
D1	LP120 i = 3					<input checked="" type="checkbox"/>
D2	LP120 i = 5					<input checked="" type="checkbox"/>
D3	LP120 i = 10					<input checked="" type="checkbox"/>

** Mounting kit: contains gear housing, motor coupling, flange and gear

HMRB Belt



ORIGA Linear Drives

Series HMRB Belt / Drive Data / Sizes 85, 110, 150, 180, 240 mm

Description Motor mounting position

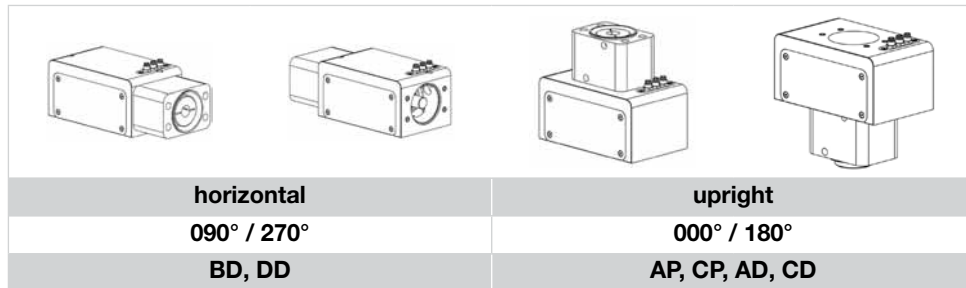

Type and orientation of the belt is given by the motor mounting position.

Technical data HMRB

Production size			HMRB08		HMRB11		HMRB15	
Motor mounting position			090° / 270°	000° / 180°	090° / 270°	000° / 180°	090° / 270°	000° / 180°
Lead constant	$s_{lin.}$	[mm]	66	66	90	90	100	125
Max. speed	$v_{max.}$	[m/s]	2		2		5	
Max. acceleration	$a_{max.}$	[m/s ²]	30		30		50	
Repeatability		[μm]			± 50			
Max. order stroke		[mm]	3,000		4,000		6,000	
Thrust force and torque								
Max. thrust force	$F_{A max.}$	[N]	295	295	630	630	1,050	630
Max. torque on drive shaft	$M_{A max.}$	[Nm]	3.1	3.1	9.0	9.0	17.0	13.0
No load torque	M_0	[Nm]	1.0	1.0	1.2	1.2	1.2	1.2

Technical data HMRB

Production size			HMRB18		HMRB24	
Motor mounting position			090° / 270°	000° / 180°	090° / 270°	000° / 180°
Lead constant	$s_{lin.}$	[mm]	130	150	160	224
Max. speed	$v_{max.}$	[m/s]	5		5	
Max. acceleration	$a_{max.}$	[m/s ²]	50		50	
Repeatability		[μm]	± 50		± 50	
Max. order stroke		[mm]	6,000		6,000	
Thrust force and torque						
Max. thrust force	$F_{A max.}$	N	1,300	1,000	4,000	3,750
Max. torque on drive shaft	$M_{A max.}$	Nm	27	24	101	134
No load torque	M_0	Nm	2.0	2.0	4.0	4.0



ORIGA Linear Drives

Series HMRB / Belt / Thrust Force / Sizes 85, 110, 150, 180, 240 mm

The permissible thrust force from the table is depending on speed level and order stroke length. The minimum thrust force value must not be exceeded in the application.

Information: Limiting the torque from the motor may avoid exceeding permitted thrust force.

HMRB thrust force

Product size			HMRB08		HMRB11		HMRB15		HMRB18		HMRB24	
Motor mounting position			090° / 270°	000° / 180°	090° / 270°	000° / 180°	090° / 270°	000° / 180°	090° / 270°	000° / 180°	090° / 270°	000° / 180°
Thrust force F_A corresponding to speed v	$F_{A(v<1 \text{ m/s})}$	[N]	295	295	630	630	1,050	630	1,300	1,000	4,000	3,750
	$F_{A(v<2 \text{ m/s})}$	[N]	295	295	550	550	990	630	1,300	1,000	4,000	3,380
	$F_{A(v<3 \text{ m/s})}$	[N]	-	-	-	-	930	630	1,300	1,000	3,650	3,140
	$F_{A(v<4 \text{ m/s})}$	[N]	-	-	-	-	890	630	1,300	1,000	3,370	2,950
	$F_{A(v<5 \text{ m/s})}$	[N]	-	-	-	-	840	630	1,300	1,000	3,200	2,800
Thrust force F_A corresponding to order stroke length OS	$F_{A(OS<1000 \text{ mm})}$	[N]	250	250	630	630	1,050	630	1,300	1,000	4,000	3,750
	$F_{A(OS<2000 \text{ mm})}$	[N]	140	140	550	550	820	490	1,000	775	4,000	3,360
	$F_{A(OS<3000 \text{ mm})}$	[N]	100	100	385	385	570	340	710	550	3,370	2,440
	$F_{A(OS<4000 \text{ mm})}$	[N]	-	-	295	295	445	265	550	430	2,860	1,880
	$F_{A(OS<5000 \text{ mm})}$	[N]	-	-	-	-	365	215	450	350	2,350	1,540
	$F_{A(OS<6000 \text{ mm})}$	[N]	-	-	-	-	305	185	380	295	2,000	1,300

Example:

HMRB18 with motor mounting position 1 (090° front), speed $v = 2 \text{ m/s}$ ($F_A = 1,300 \text{ N}$)

and order stroke length OS = 2,500 mm ($F_A = 710 \text{ N}$).

The maximum permissible thrust force $F_A = 710 \text{ N}$ must not be exceeded.



ORIGA Linear Drives

Series HMRB / Belt / Dimensions / Sizes 85, 110, 150, 180, 240 mm

Dimensions

“Basic” profile

View A

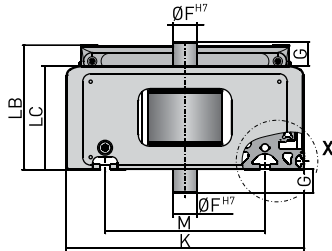

View B

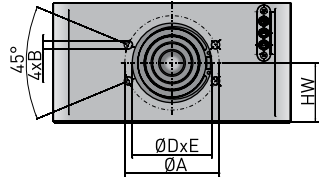

“Reinforced” profile

View A

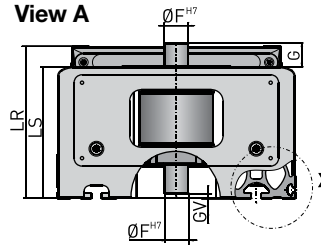

View X

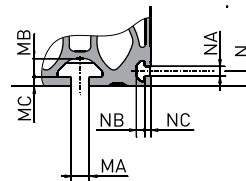

Dimensions carrier

B 3-PIN M8 connections

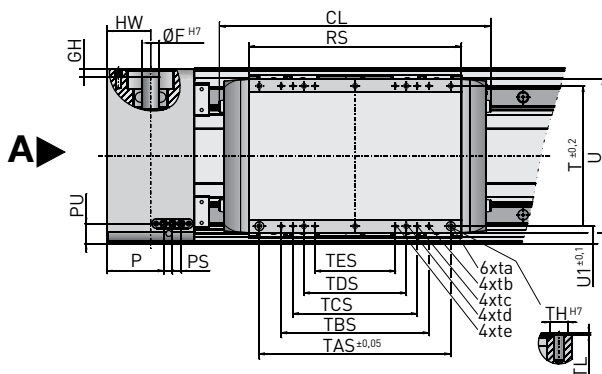
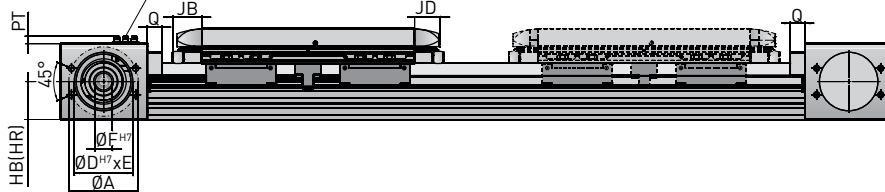

Dimension table - HMRB

Size		Ø A	B	Ø D ^{H7}	E	Ø F ^{H7}	G	GV	GH	HB	HR	HW	K	LB	LC
HMRB08	[mm]	42.0	M4	34.0	2.5	10.0	13.5	2.5	3.0	26.5	37.5	25.0	85.0	60.0	52.5
HMRB11	[mm]	51.0	M6	39.0	1.2	12.0	20.0	0.0	5.0	30.0	50.0	31.0	110.0	69.5	60.5
HMRB15	[mm]	72.0	M8	54.0	2.1	15.0	19.3	7.0	5.5	36.5	60.5	45.0	150.0	90.0	74.0
HMRB18	[mm]	80.0	M8	64.0	4.0	18.0	21.8	1.5	8.0	45.0	68.0	50.0	180.0	111.5	93.5
HMRB24	[mm]	95.0	M10	80.0	2.5	24.0	24.0	4.0	11.0	52.5	80.5	60.0	240.0	125.0	104.5

Dimension table - HMRB

Product size	LR	LS	M	MA	MB	MC	N	NA	NB	NC	P	PS	PT	PU	Q
HMRB08 [mm]	71.0	63.5	50.0	5.2	4.5	1.5	4.5	3.4	3.0	2.5	23.8	12.0	9.0	12.0	16.0
HMRB11 [mm]	89.5	80.5	70.0	5.2	4.5	1.8	4.5	3.4	3.0	2.5	30.8	12.0	9.0	17.0	20.0
HMRB15 [mm]	114.0	98.0	96.0	6.2	6.8	3.0	6.5	5.2	4.6	3.5	48.0	12.0	9.0	21.0	20.0
HMRB18 [mm]	134.5	116.5	116.0	8.0	7.8	4.5	8.5	5.2	4.5	3.5	58.0	12.0	9.0	28.0	20.0
HMRB24 [mm]	153.0	132.5	161.0	10.0	10.2	5.3	8.5	5.2	4.5	3.5	78.0	12.0	9.0	28.6	20.0

Dimension table - carrier standard HMRB

Product size	JB	JD	CL	RS	T	TAS	ta	TBS	tb	TCS	tc	TDS
HMRB08 [mm]	33.5	30.0	195.0	128.0	74.0	97.0	M4x12	70.0	M4x12	40.0	M4x12	-
HMRB11 [mm]	37.5	34.0	225.0	150.0	96.0	122.0	M5x12	97.0	M5x12	65.0	M5x12	25.0
HMRB15 [mm]	37.5	34.0	266.0	191.0	120.0	170.0	M5x12	122.0	M5x12	-	-	70.0
HMRB18 [mm]	40.0	34.0	311.0	231.0	150.0	202.0	M6x12	170.0	M5x10	122.0	M5x10	90.0
HMRB24 [mm]	40.0	34.0	371.0	291.0	192.0	262.0	M8x16	202.0	M6x12	170.0	M5x10	140.0

Dimension table - carrier standard HMRB

Product size	td	TES	te	ØTK ^{H7}	TL	U	U1
HMRB08 [mm]	-	-	-	7.0	1.5	83.0	5.5
HMRB11 [mm]	M5x12	-	-	7.0	1.5	105.0	7.0
HMRB15 [mm]	M5x12	-	-	7.0	1.5	135.0	15.0
HMRB18 [mm]	M6x12	-	-	9.0	1.5	165.0	15.0
HMRB24 [mm]	M8x16	122.0	M5x10	12.0	1.5	210.0	24.0

ORIGA Linear Drives

Series HMRB / Weight, Mass and Inertia

Weight and mass HMRB

Product size			HMRB08				HMRB11				HMRB15			
Weight of actuator														
Version actuator (see order code)			B	C	R	S	B	C	R	S	B	C	R	S
Weight. 0 - order stroke	m_0	[kg]	2.4	2.7	3.1	3.4	4.4	4.8	6.1	6.5	6.7	7.5	9.4	10.3
Weight per 1 m order stroke	m_{mt}	[kg/m]	3.0	4.0	4.0	5.0	5.4	6.4	7.6	8.6	8.2	9.9	11.5	13.3
Moving mass carrier														
Version of carrier (see order code)			0	1	0	1	0	1	0	1	0	1	0	1
Weight carrier	m_c	[kg]	0.9	0.7	1.7	1.3	2.7	1.9	2.7	1.9	2.7	1.9	2.7	1.9

Weight and mass HMRB

Product size			HMRB18				HMRB24			
Weight of actuator										
Version actuator (see order code)			B	C	R	S	B	C	R	S
Weight. 0 - order stroke	m_0	[kg]	11.6	12.8	15.6	16.7	21.5	23.1	28.0	29.6
Weight per 1 m order stroke	m_{mt}	[kg/m]	12.8	15.1	16.5	18.7	21.6	24.4	26.7	29.5
Moving mass carrier										
Version of carrier (see order code)			0	1	0	1	0	1	0	1
Weight carrier	m_c	[kg]	4.6	3.7	9.0	7.2	9.0	7.2	9.0	7.2

Total mass HMRB: $m_{tot} = m_0 + m_c + \text{order stroke} * m_{mt}$

Inertia HMRB

Product size			HMRB08		HMRB11		HMRB15	
Motor mounting position (see order code)			090°/270°	000°/180°	090°/270°	000°/180°	090°/270°	000°/180°
Inertia								
Inertia 0 - order stroke	J_0	[kgmm ²]	14	14	52	52	102	145
Inertia per 1 m order stroke	J_{mt}	[kgmm ² /m]	10	10	41	41	79	79
Inertia per 1 kg moving mass	J_{kg}	[kgmm ² /kg]	110	110	205	205	253	396

Inertia HMRB

Product size			HMRB18		HMRB24	
Motor mounting position (see order code)			090°/270°	000°/180°	090°/270°	000°/180°
Inertia						
Inertia 0 - order stroke	J_0	[kgmm ²]	297	394	1,178	2,758
Inertia per 1 m order stroke	J_{mt}	[kgmm ² /m]	134	222	689	900
Inertia per 1 kg moving mass	J_{kg}	[kgmm ² /kg]	428	570	649	1,271

Inertia total HMRB: $J_{tot} = J_0 + \text{order stroke} * J_{mt} + m_c * J_{kg} + m * J_{kg}$



ORIGA Linear Drives

Series HMRB Belt / Order stroke / Sizes 85, 110, 150, 180, 240 mm

Stroke depending dimensions

- ES = Effective Stroke
- SS = Safety Stroke
- CD = Carriage distance
- CL = Carriage length Standard
- S = Stroke
- OS = Order Stroke
- OAL = Over All Length

Option Carrier Standard

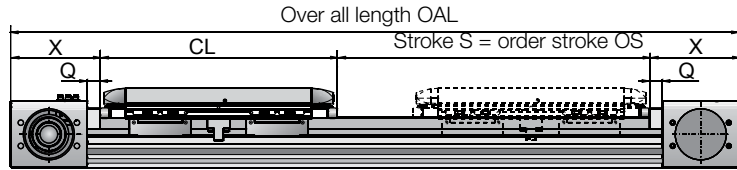

Order stroke OS = Effective stroke ES + 2 x Safety stroke SS

Over all length OAL = Order stroke OS + Carrier length CL + 2 x End cap length X

Option Carrier Tandem

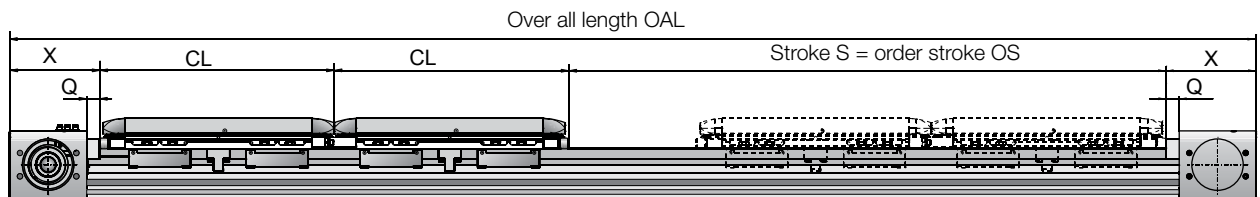

Order stroke OS = Effective stroke ES + 2 x Safety stroke SS + Carrier distance CD (not shown)

Over all length OAL = Order stroke OS + 2 x Carrier length CL + 2 x End cap length X

Option Carrier Bi-part for opposite movements

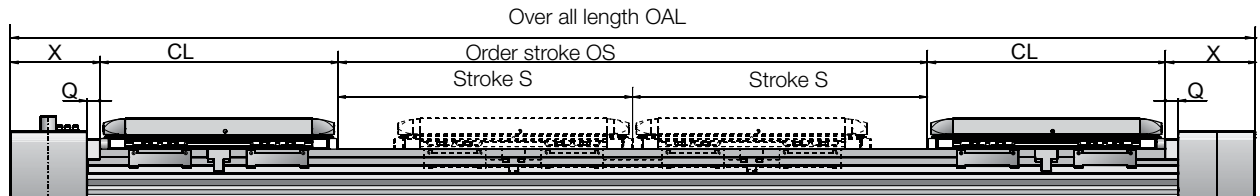

Order stroke OS = 2 x Stroke S = 2 x Effective stroke ES + 4 x Safety stroke SS + Carrier distance CD (not shown)

Over all length OAL = Order stroke OS + 2 x Carrier length CL + 2 x End cap length X

Dimensions - Carriage and end cap HMRB

Product size	CL	Q	X
HMRB08 [mm]	195.0	16.0	74.0
HMRB11 [mm]	225.0	20.0	85.0
HMRB15 [mm]	266.0	20.0	110.0
HMRB18 [mm]	311.0	20.0	120.0
HMRB24 [mm]	371.0	20.0	140.0



ORIGA Linear Drives

Product series HMRB

Order code		HMR	B	15	B	BD	0	-	0000	-	0	0	0	0	00	00
Type of actuator																
B	Belt															
Product size																
08	Product width 085 mm															
11	Product width 110 mm															
15	Product width 150 mm															
18	Product width 180 mm															
24	Product width 240 mm															
Actuator design																
B	Basic Profile with ball bearing guide Standard															
C	Basic Profile with ball bearing guide and IP54 with outer cover															
R	Reinforced Profile with ball bearing guide Standard															
S	Reinforced Profile with ball bearing guide and IP54 with outer cover															
Motor mounting position and drive shaft design																
BD	090° front with double plain shaft															
DD	270° back with double plain shaft															
AP	000° up with single plain shaft															
CP	180° down with single plain shaft															
AD	000° up with double plain shaft															
CD	180° down with double plain shaft															
Carriage design																
0	Standard															
1	Tandem															
2	Bi-part															
Order stroke																
0000	4 digits input in mm															
Home Sensor (one sensor)																
0	No home sensor															
1	R2NO-I: Reed, 2 wire, NO, internal															
A	P3NO-I: PNP, 3 wire, NO, internal															
K	N3NO-I: NPN, 3 wire, NO, internal															
3	R2NO-P: Reed, 2 wire, NO, M8 plug, 0.3 m cable, external															
C	P3NO-P: PNP, 3 wire, NO, M8 plug, 0.3 m cable, external															
M	N3NO-P: NPN, 3 wire, NO, M8 plug, 0.3 m cable, external															
5	R2NO-FL3: Reed, 2 wire, NO, Flying leads, 3 m cable, external															
E	P3NO-FL3: PNP, 3 wire, NO, Flying leads, 3 m cable, external															
P	N3NO-FL3: NPN, 3 wire, NO, flying leads, 3 m cable, external															
7	R2NO-FL10: Reed, 2 wire, NO, flying leads, 10 m cable, external															
G	P3NO-FL10: PNP, 3 wire, NO, flying leads, 10 m cable, external															
R	N3NO-FL10: NPN, 3 wire, NO, flying leads, 10 m cable, external															
Limit Sensor (one sensor each end)																
0	No limit sensor															
2	R2NC-I: Reed, 2 wire, normally close, internal															
B	P3NC-I: PNP, 3 wire, normally close, internal															
L	N3NC-I: NPN, 3 wire, normally close, internal															
4	R2NC-P: Reed, 2 wire, normally close, M8 plug, 0.3 m cable, external															
D	P3NC-P: PNP, 3 wire, normally close, M8 plug, 0.3 m cable, external															
N	N3NC-P: NPN, 3 wire, normally close, M8 plug, 0.3 m cable, external															
6	R2NC-FL3: Reed, 2 wire, normally close, flying leads, 3 m cable, external															
F	P3NC-FL3: PNP, 3 wire, normally close, flying leads, 3 m cable, external															
Q	N3NC-FL3: NPN, 3 wire, normally close, flying leads, 3 m cable, external															
8	R2NC-FL10: Reed, 2 wire, normally close, flying leads, 10 m cable, external															
H	P3NC-FL10: PNP, 3 wire, normally close, flying leads, 10 m cable, external															
S	N3NC-FL10: NPN, 3 wire, normally close, flying leads, 10m cable, external															

Mounting kits*

Product size HMRB		08	11	15	18	24								
00	No mounting kit or motor mounting	<input checked="" type="checkbox"/>	<input checked="" type="checkbox"/>	<input checked="" type="checkbox"/>	<input checked="" type="checkbox"/>	<input checked="" type="checkbox"/>								
Mounting kit Gear				15	18	24								
A7	PS60			<input checked="" type="checkbox"/>	<input checked="" type="checkbox"/>									
A8	PS90				<input checked="" type="checkbox"/>									
A9	PS115					<input checked="" type="checkbox"/>								
C0	LP050	<input checked="" type="checkbox"/>	<input checked="" type="checkbox"/>											
C1	PV60-TA / LP070		<input checked="" type="checkbox"/>	<input checked="" type="checkbox"/>	<input checked="" type="checkbox"/>									
C2	PV90-TA / LP090				<input checked="" type="checkbox"/>									
C3	PV115-TA / LP120					<input checked="" type="checkbox"/>								
Mounting kit Motor							Ax	Bx	Cx	Dx	Fx	Gx	Hx	
A2	SMx60 8/11, MH56 5/11, NX2	<input checked="" type="checkbox"/>	<input checked="" type="checkbox"/>	<input checked="" type="checkbox"/>			<input checked="" type="checkbox"/>	<input checked="" type="checkbox"/>			<input checked="" type="checkbox"/>			
A3	SMx82 8/14		<input checked="" type="checkbox"/>	<input checked="" type="checkbox"/>	<input checked="" type="checkbox"/>			<input checked="" type="checkbox"/>	<input checked="" type="checkbox"/>		<input checked="" type="checkbox"/>	<input checked="" type="checkbox"/>	<input checked="" type="checkbox"/>	
A4	SMx100 5/19, MH105 5/19			<input checked="" type="checkbox"/>	<input checked="" type="checkbox"/>	<input checked="" type="checkbox"/>			<input checked="" type="checkbox"/>	<input checked="" type="checkbox"/>		<input checked="" type="checkbox"/>	<input checked="" type="checkbox"/>	
A5	SMx115 5/24, SMx142 5/24, MH145 5/24				<input checked="" type="checkbox"/>	<input checked="" type="checkbox"/>			<input checked="" type="checkbox"/>	<input checked="" type="checkbox"/>			<input checked="" type="checkbox"/>	
AG	SMx60 5/11, MH70 5/11, NX3	<input checked="" type="checkbox"/>	<input checked="" type="checkbox"/>				<input checked="" type="checkbox"/>	<input checked="" type="checkbox"/>			<input checked="" type="checkbox"/>			
AL	MPP092							<input checked="" type="checkbox"/>	<input checked="" type="checkbox"/>					
AK	AK - SMx115 7/24, MH105 9/24, NX6								<input checked="" type="checkbox"/>	<input checked="" type="checkbox"/>				<input checked="" type="checkbox"/>
AJ	SMx82 8/19, MH105 7/19, NX4								<input checked="" type="checkbox"/>	<input checked="" type="checkbox"/>			<input checked="" type="checkbox"/>	
AH	SMx60 8/9, MH56 5/9	<input checked="" type="checkbox"/>	<input checked="" type="checkbox"/>				<input checked="" type="checkbox"/>	<input checked="" type="checkbox"/>			<input checked="" type="checkbox"/>			
B0	motor mounting kit (75 / M6 / 60 / 3 / 14 / 30)	<input checked="" type="checkbox"/>						<input checked="" type="checkbox"/>	<input checked="" type="checkbox"/>		<input checked="" type="checkbox"/>			
B1	motor mounting kit (90 / M5 / 60 / 3 / 11 / 23)	<input checked="" type="checkbox"/>	<input checked="" type="checkbox"/>				<input checked="" type="checkbox"/>	<input checked="" type="checkbox"/>			<input checked="" type="checkbox"/>			
B2	motor mounting kit (90 / M5 / 60 / 3 / 14 / 30)	<input checked="" type="checkbox"/>	<input checked="" type="checkbox"/>					<input checked="" type="checkbox"/>	<input checked="" type="checkbox"/>					
B3	motor mounting kit (95 / M6 / 50 / 3 / 14 / 30)	<input checked="" type="checkbox"/>	<input checked="" type="checkbox"/>					<input checked="" type="checkbox"/>	<input checked="" type="checkbox"/>		<input checked="" type="checkbox"/>	<input checked="" type="checkbox"/>		
B4	motor mounting kit (90 / M6 / 70 / 3 / 16 / 40)							<input checked="" type="checkbox"/>	<input checked="" type="checkbox"/>					
B8	motor mounting kit (63 / M4 / 40 / 3 / 9 / 20)						<input checked="" type="checkbox"/>							

* Mounting kit consisting coupling housing, motor coupling and flange

Mounting position limit sensor

0	No limit sensor
1	10 mm
2	20 mm
3	30 mm
4	40 mm
5	50 mm
6	60 mm
7	70 mm
8	80 mm
9	90 mm
A	100 mm
B	110 mm
C	120 mm
D	130 mm
E	140 mm
F	150 mm
G	160 mm
H	170 mm
J	180 mm
K	190 mm
L	200 mm

Gear mounting**

Product size HMRB		08	11	15	18	24
00	No Gear mounting	<input checked="" type="checkbox"/>	<input checked="" type="checkbox"/>	<input checked="" type="checkbox"/>	<input checked="" type="checkbox"/>	<input checked="" type="checkbox"/>
A2	LP050 i = 5	<input checked="" type="checkbox"/>	<input checked="" type="checkbox"/>			
A3	LP050 i = 10	<input checked="" type="checkbox"/>	<input checked="" type="checkbox"/>			
B1	LP070 i = 3		<input checked="" type="checkbox"/>	<input checked="" type="checkbox"/>	<input checked="" type="checkbox"/>	
B2	LP070 i = 5		<input checked="" type="checkbox"/>	<input checked="" type="checkbox"/>	<input checked="" type="checkbox"/>	
B3	LP070 i = 10		<input checked="" type="checkbox"/>	<input checked="" type="checkbox"/>	<input checked="" type="checkbox"/>	
C1	LP090 i = 3				<input checked="" type="checkbox"/>	
C2	LP090 i = 5				<input checked="" type="checkbox"/>	
C3	LP090 i = 10				<input checked="" type="checkbox"/>	
D1	LP120 i = 3					<input checked="" type="checkbox"/>
D2	LP120 i = 5					<input checked="" type="checkbox"/>
D3	LP120 i = 10					<input checked="" type="checkbox"/>
F1	PS60-003-S2 i=3			<input checked="" type="checkbox"/>		
F2	PS60-005-S2 i=3			<input checked="" type="checkbox"/>		
F3	PS60-010-S2 i=3			<input checked="" type="checkbox"/>		
G1	PS90-003-S2 i=3				<input checked="" type="checkbox"/>	
G2	PS90-005-S2 i=3				<input checked="" type="checkbox"/>	
G3	PS90-010-S2 i=3				<input checked="" type="checkbox"/>	
H1	PS115-003-S2 i=3					<input checked="" type="checkbox"/>
H2	PS115-005-S2 i=3					<input checked="" type="checkbox"/>
H3	PS115-010-S2 i=3					<input checked="" type="checkbox"/>

* Mounting kit consisting coupling housing, motor coupling, flange and gear

HMR Options



ORIGA Linear Drives

HMR Series / Option / Protection Class

Versions:

standard: without cover

IP54: with cover

HMR was developed for various environment conditions.

HMR can be equipped with a cover to comply with IP54 protection class if a higher rating is required.

Version – standard

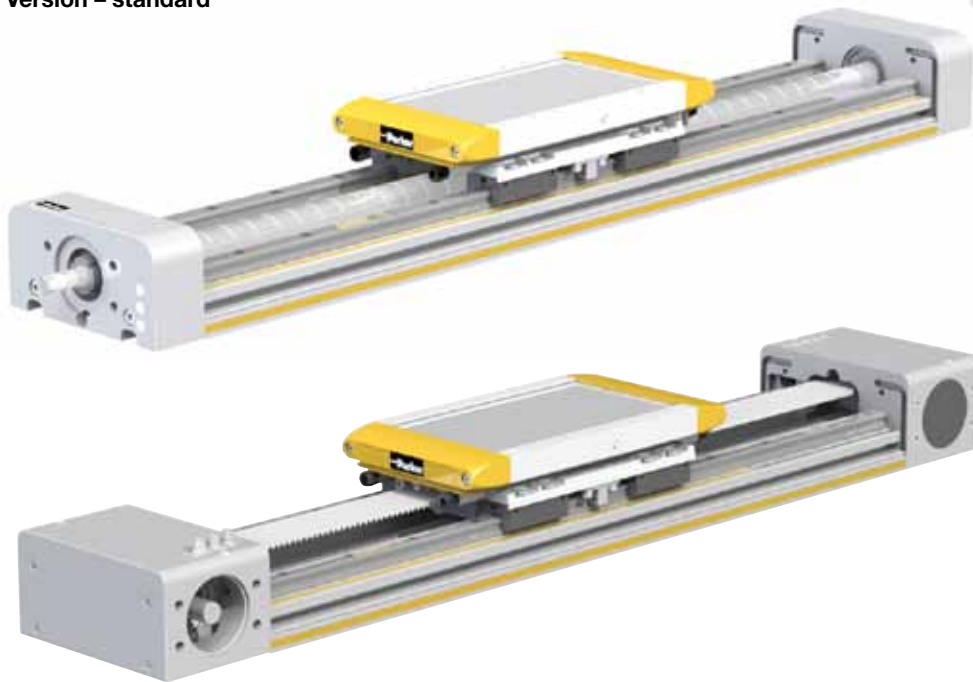

Version – protection class IP54



ORIGA Linear Drives

HMR series / Option / Impact protection

HMR can be equipped with impact protection. The mounted structure shock absorbers can compensate the energy released by unintentional impact and afford protection against mechanical damage.

Two structure shock absorbers are fitted to each side of the carriage prior to delivery.

Shock absorbers for impact protection

Product size		HMRx08	HMRx11	HMRx15	HMRx18	HMRx24
Shock absorber		TA12-5	TA12-5	TA12-5	TA17-7	TA17-7
Energy absorption	[Nm/stroke]	3.0	3.0	3.0	8.5	8.5
Maximum stroke	[mm]	5.0	5.0	5.0	7.0	7.0

Distance-force and energy-distance characteristic curve (dynamic) - production sizes HMRx08, HMRx11, HMRx15

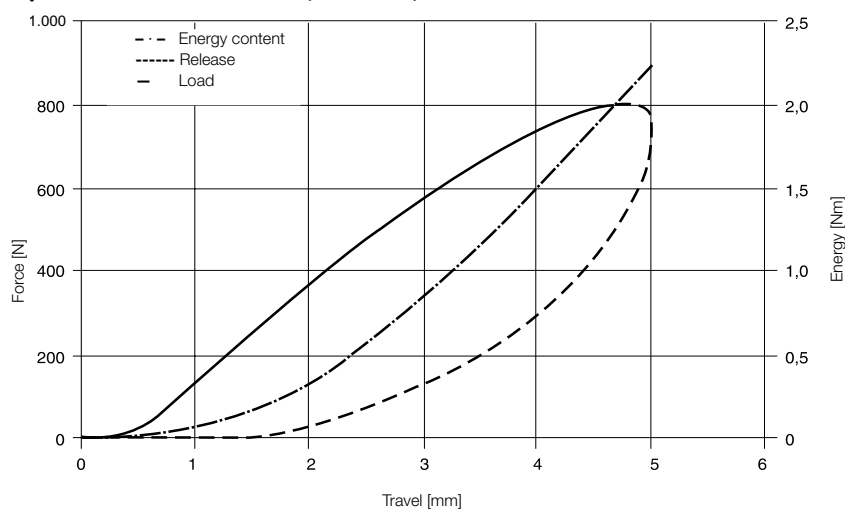

Distance-force and energy-distance characteristic curve (dynamic) - production sizes HMRx18, HMRx24

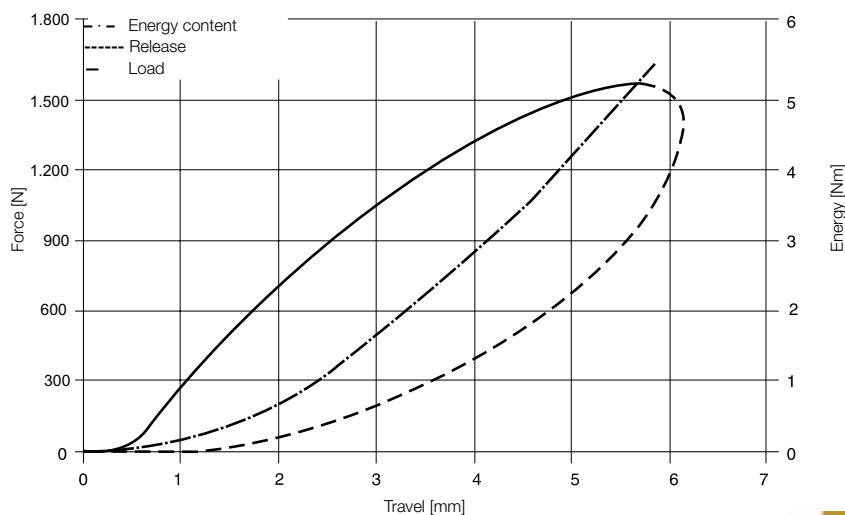

Magnetic Field Sensors



Type P8S

The new generation of t-slot sensors convince with easy mounting avoiding special tools and with a drop in moutange. Due to new electronic the hysteresis is very small and allows a very accurate switching point.

Magnetic sensors are used for contactless electric sensing of the carrier position, e.g. for end or homing positions of a linear acutator. The field of magnets mounted as standard into the carriage activate the sensor.

Electric Service Life

Protective Measures

Type RS magnetic sensors are sensitive to excessive currents and inductions. With high switching frequencies and inductive loads such as relays, solenoid valves or lifting magnets, service life will be greatly reduced.

With resistive and capacitive loads with high switch-on current, such as light bulbs, a protective resistor should be fitted. This also applies to long cable lengths and voltages over 100 V.

In the switching of inductive loads such as relays, solenoid valves and lifting magnets, voltage peaks (transients) are generated which must be suppressed by protective diodes, RC loops or varistors.

Connection Examples

Load with protective circuits

- (a) Protective resistor for light bulb
- (b) Freewheel diode on inductivity
- (c) Varistor on inductivity
- (d) RC element on inductivity



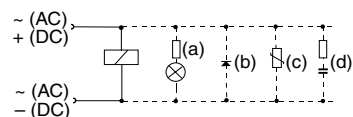

For the type EST, external protective circuits are not normally needed.



The possible speed of the load-bearing element or carriage must take the minimum response time of downstream devices into account.

Contact travel is considered accordingly in the calculations.

$\text{Minimum response time} = \frac{\text{Contact travel}}{\text{Overrun speed}}$

Series		P8S-G ¹⁾ - insertable into T-Slot from top							
Type		M8R ²⁾		FL ³⁾		M8R ²⁾	FL ³⁾		
									
CE. cULus. RoHs									
Output Function		0.3 m Cable	3 m Cable	10 m Cable	0.3 m Cable	3 m Cable	10 m Cable		
PNP	NO	P8S-GPCHX	P8S-GPFAX	P8S-GPFDX					
	NC	P8S-GQCHX	P8S-GQFAX	P8S-GQFDX					
NPN	NO	P8S-GNCHX	P8S-GNFAX	P8S-GNFDX					
	NC	P8S-GMCHX	P8S-GMFAX	P8S-GMFDX					
REED	NO				P8S-GRCHX	P8S-GRFAX	P8S-GRFDX		
	NC				P8S-GECNX	P8S-GEFFX	P8S-GEFRX		
Technical Data		Electrical				Reed			
Electrical Characteristics									
Electric Configuration		3-pole				2-pole			
Indicator LED yellow		yes				yes (not NC)			
Operating Voltage U _b [V]		10 - 30 DC				10 - 30 AC/DC			
Ripple of U _b [%]		≤ 10				≤ 10			
Voltage Drop U _a [V]		≤ 2				≤ 3			
Power Consumption ⁴⁾ [mA]		≤ 10							
Continuous Current I _a [mA]		≤ 100				≤ 500 (NO ≤ 100)			
Max. Switching Capacity [W]		≤ 6				≤ 10			
Switchable Capacity Load @ 100W @ 24VDC [nF]						100			
Switching Frequency [Hz]		≤ 1,000				≤ 400			
Time delay before availability [ms]		0.5 / 0.5				1.5 / 0.5			
Sensitivity [mT]		2.8				3			
Hysteresis [mT]		0.7				≥ 0.2			
EMC ⁶⁾		yes				yes			
Lifetime		unlimited				≥ 20*10 ⁶ Cycles			
Short Circuit Protection ⁵⁾									
Reverse Polarity Protection		yes							
Power-Up Pulse Suppression									
Protection for Inductive Load									
ATEX Version		on request							
Mechanical Characteristics									
Housing		PA12							
Cable Type		PUR / black							
Cable Cross Section [mm ²]		Connector 3-pole	3 x 0.14	3 x 0.14	Connector 3-pole	2 x 0.14	2 x 0.14		
Bending Radius Fixed Installation [mm]		≥ 30							
Bending Radius Moving [mm]						≥ 45			
Shock Resistance									
Protection ⁷⁾ [IP]		67							
Ambient Temperature Range T _a [°C]		-25 ... +75							
Shock ⁸⁾ / Vibration ⁹⁾		30 g, 11 ms / 10 to 55 Hz, 1 mm							

¹⁾ without OSP-E..STR

²⁾ plug M8 with rotatable nut

³⁾ Cable with Flying Leads

⁴⁾ unloaded U_b = 24V

⁵⁾ clocked

⁹⁾ to EN 60529

⁷⁾ to EN 60529

⁸⁾ to EN 60068-2-27

⁹⁾ to EN 60068-2-6

Switching function and electrical connection

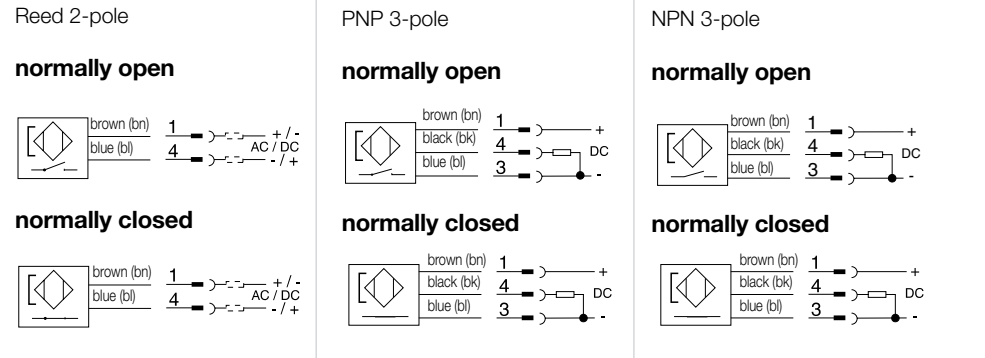

Dimensions (mm) - Type P8S

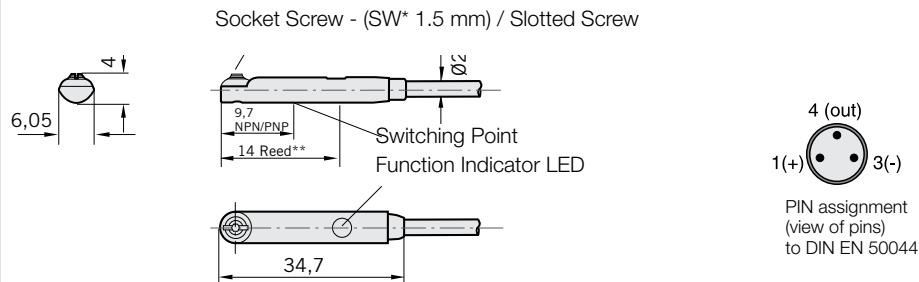

P8S-... cable with flying leads

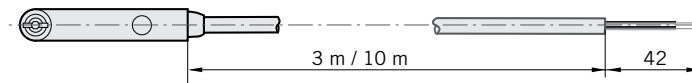

P8S-... cable with M8 rotatable

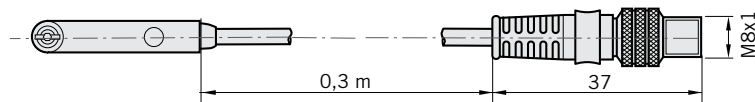

* = Wrench Size
** = Switching Point Reed

Installation for Magnetic T-Slot Sensors

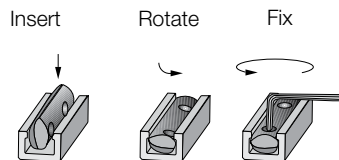

Connection Cables suitable for cable chain

M8 Plug with 5 m cable	KL3186*
M8 Plug with 10 m cable	KL3217*
M8 Plug with 15 m cable	KL3216*

* Detailed specifications for KL-Series on request.



HMR Accessories



ORIGA Linear Drives

HMR Series / Accessories / Coupling housing

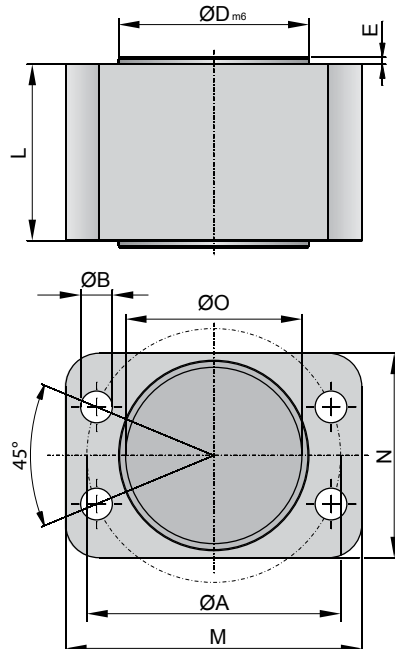

Dimension table - Coupling housing long HMRS / HMRB [mm]

Product size	$\varnothing A$	$\varnothing B$	$\varnothing D_{m6}$	E	$\varnothing O$	L	M	N	Order no.
HMRx08	42	4.5	34	2	30	28	49	37	56568FIL
HMRx11	51	6.6	39	1	35	37	60	42	56566FIL
HMRx15	72	9.0	54	2	50	54	84	58	50353FIL
HMRx18	80	9.0	64	2	60	70	90	68	50655FIL
HMRx24	95	11.0	80	2	77	85	107	85	56415FIL

- suitable for all types of HMRS
- suitable for HMR with motor orientation 000° top (HMRBxxxAP; HMRBxxxAD)
- suitable for HMR with motor orientation 180° bottom and profile version Basic (HMRBxxBCP; HMRBxxBCD; HMRBxxCCP; HMRBxxCCD)

Dimension table - Coupling housing short HMRB [mm]

Product size	$\varnothing A$	$\varnothing B$	$\varnothing D_{m6}$	E	$\varnothing O$	L	M	N	Order no.
HMRB08	42	4.5	34	2	30	13	49	37	56567FIL
HMRB08 *	42	4.5	34	2	30	17	49	37	56569FIL
HMRB11	51	6.6	39	1	35	15	60	42	56565FIL
HMRB15	72	9.0	54	2	50	30	84	58	56412FIL
HMRB18	80	9.0	64	2	60	42	90	68	56413FIL
HMRB24	95	11.0	80	2	77	60	107	85	56414FIL

- suitable for HMR with motor orientation 090° front and 270° rear (HMRBxxxBD; HMRBxxxDD)
- suitable for HMR with motor orientation 180° bottom re-inforced profile (HMRBxxRCP; HMRBxxRCD; HMRBxxSCP; HMRBxxSCD)



ORIGA Linear Drives

HMR series / Accessories / Motor coupling

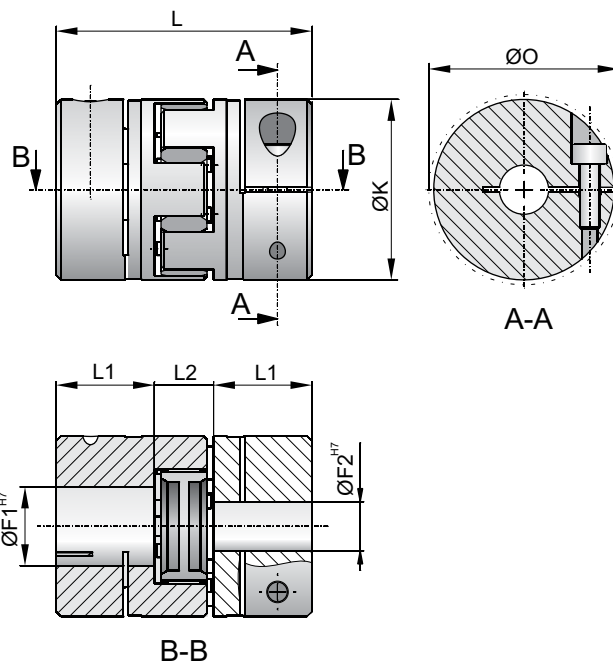

Ball screw

Dimension table - motor coupling HMRS [mm]

Product size	F ₁	F ₂	F	K	L	L ₁	L ₂	Ø O	Order no.
HMRS08	6	9	5 - 12	25	34	11	12	27.5	56562FIL
HMRS11	10	9	6 - 16	30	35	11	13	32.5	13210FIL
HMRS15	12	9	8 - 24	40	66	25	16	58.0	56400FIL
HMRS18	15	14	10 - 28	55	78	30	18	68.0	56402FIL
HMRS24	20	14	14 - 38	65	90	35	20	73.0	56510FIL

Belt

Dimension table - motor coupling HMRB [mm]

Product size	F ₁	F ₂	F	K	L	L ₁	L ₂	Ø O	Order no.
HMRB08	10	9	5 - 12	25	34	11	12	27.5	56563FIL
HMRB11	12	9	6 - 16	30	35	11	13	32.5	56560FIL
HMRB15	15	10	8 - 24	40	66	25	16	58.0	16239FIL
HMRB18	18	14	10 - 28	55	78	30	18	68.0	56411FIL
HMRB24	24	15	14 - 38	65	90	35	20	73.0	16260FIL



ORIGA Linear Drives

HMR series / Accessories / Mountings

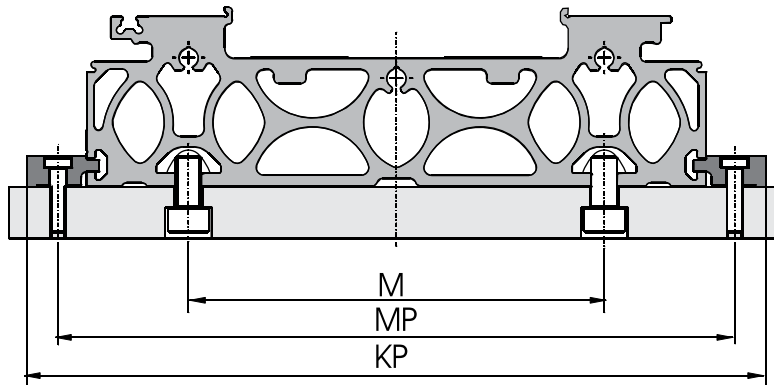

Dimension table - Product width HMR [mm]

Product size	T-slot fixture		T-slot mounting
	MP	KP	M
HMRx08	97	115	50
HMRx11	122	140	70
HMRx15	170	190	96
HMRx18	202	226	116
HMRx24	262	286	161

Holding force per mounting set [N]

Product size	Mounting bracket				T-nut			
	In longitudinal direction of the actuator*	Screw 2x	Tightening torque [Nm]	Max. load per screw	In longitudinal direction of the actuator*	Screw 1x	Tightening torque [Nm]	Max. load per screw
HMRx08	800	M4	3	900	1,000	M5	6	1,200
HMRx11	800	M4	3	900	1,000	M5	6	1,200
HMRx15	1,820	M5	6	1,200	1,600	M6	10	1,700
HMRx18	2,610	M6	10	1,700	2,700	M8	20	3,400
HMRx24	2,610	M6	10	1,700	3,200	M10	40	5,500

*A friction factor of 0.15 between profile and mounting surface was taken as a basis for the calculation of the forces that can be transmitted in longitudinal direction, Screw property class 8.8.

ORIGA Linear Drives

HMR series / Accessories / T-slot mounting / T-slot fixture

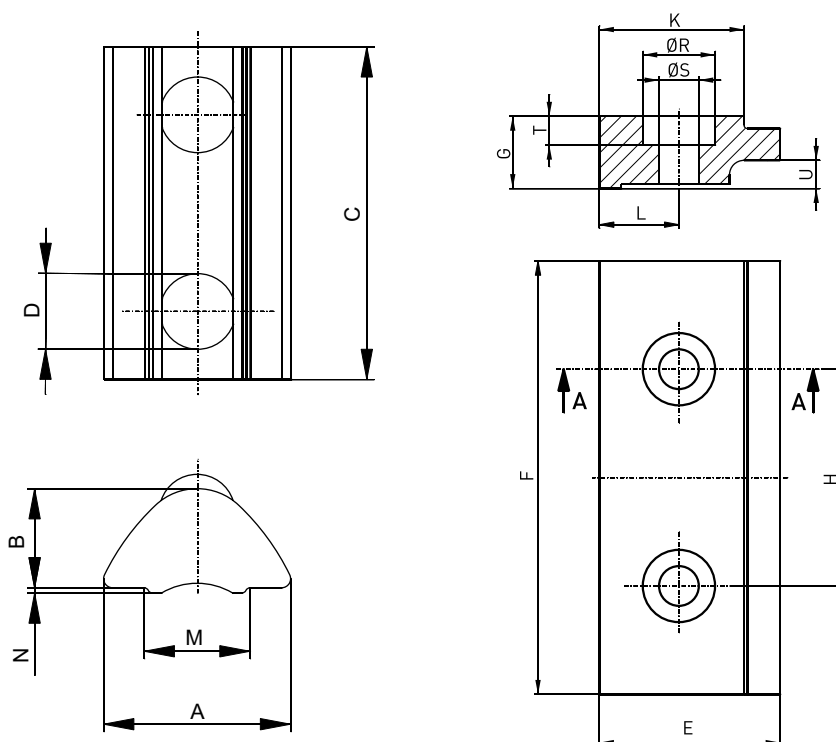

Dimension table - T-slot mounting HMR [mm]

Product size	A	B	C	Ø D	M	N	Order no. *
HMRx08	8.0	4.0	11.5	M5	5.0	0.5	56351FIL
HMRx11	8.0	4.0	11.5	M5	5.0	0.5	56351FIL
HMRx15	10.5	6.4	22.5	M6	6.4	0.6	56352FIL
HMRx18	13.5	6.7	22.5	M8	8.5	1.0	56353FIL
HMRx24	16.5	8.9	28.5	M10	10.5	1.0	56354FIL

* Packing unit 10 pc

Dimension table - T-slot fixture HMR [mm]

Product size	E	F	G	H	K	L	Ø R	Ø S	T	U	Order no. *
HMRx08	18.0	40.0	7.5	20.0	15.0	9.0	0.0	4.5	0.0	2.8	56363FIL
HMRx11	18.0	40.0	7.5	20.0	15.0	9.0	0.0	4.5	0.0	2.8	56363FIL
HMRx15	25.0	60.0	10.0	30.0	20.0	11.0	10.0	5.5	4.0	3.9	56355FIL
HMRx18	28.0	80.0	12.0	40.0	23.0	12.0	11.0	6.6	4.7	5.9	56356FIL
HMRx24	28.0	80.0	12.0	40.0	23.0	12.0	11.0	6.6	4.7	5.9	56356FIL

* Packing unit 1 pair incl. screws

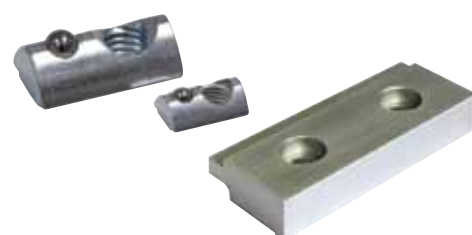

Drive Combinations

Ball Screw Drive



Type of drive		Coupling housing	Motor coupling	Motor flange
HMRS-08		56568FIL	56553FIL	56590FIL
			56555FIL	56594FIL
HMRS-11		56566FIL	12074FIL	56588FIL
			10801FIL	56592FIL
HMRS-15		50353FIL	16498FIL	56528FIL
			16866FIL	50358FIL
HMRS-18		50655FIL	56402FIL	56504FIL
			56403FIL	50660FIL
HMRS-24		56415FIL	56513FIL	56515FIL
			56512FIL	56462FIL
			56512FIL	56462FIL



	Servo motor	Motor cable	Resolver cable	Controller	Connector kit
	SMH60 60 1,4 8 11 S 2ID 65 4	MOK54/03	REK41/03	C3S 015 V4 F10 I11 T11 M00	ZBH02/02
	SMH82 60 03 8 14 S 2ID 65 4	MOK54/03	REK41/03	C3S 038 V4 F10 I11 T11 M00	
	SMH60 60 1,4 8 11 S 2ID 65 4	MOK54/03	REK41/03	C3S 015 V4 F10 I11 T11 M00	ZBH02/02
	SMH82 60 03 8 14 S 2ID 65 4	MOK54/03	REK41/03	C3S 038 V4 F10 I11 T11 M00	
	SMH60 60 1,4 8 11 S 2ID 65 4	MOK54/03	REK41/03	C3S 015 V4 F10 I11 T11 M00	ZBH02/02
	SMH82 60 03 8 14 S 2ID 65 4	MOK54/03	REK41/03	C3S 038 V4 F10 I11 T11 M00	
	SMH82 60 03 8 14 S 2ID 65 4	MOK54/03	REK41/03	C3S 038 V4 F10 I11 T11 M00	ZBH02/02
	SMH100 56 06 5 19 S 2ID 65 4	MOK54/03	REK41/03	C3S 075 V4 F10 I11 T11 M00	
	SMH100 56 06 5 19 S 2ID 65 4	MOK54/03	REK41/03	C3S 075 V4 F10 I11 T11 M00	ZBH02/02
	SMH115 56 10 5 24 S 2I 65 4	MOK57/03	REK41/03	C3S 150 V4 F10 I11 T11 M00	
	SMH142 56 15 5 24 S 2I 65 4	MOK57/03	REK41/03	C3S 150 V4 F10 I11 T11 M00	

Drive Combinations

Belt Drive



Type of drive	Profile version	Motor mounting position	Example	Coupling housing	Motor coupling	Motor flange
HMRB-08	B, C, R, S	BD = 090° front	HMRB08BBD...	56567FIL	56557FIL	56585FIL
		DD = 270° back	HMRB08BDD...			
	B, C	AP, AD = 000° up	HMRB08BAP...	56568FIL		
	B, C	CP, CD = 180° down	HMRB08BCP...			
	R, S	AP, AD = 000° up	HMRB08RAP...	56569FIL		
R, S	CP, CD = 180° down	HMRB08RCP...				
HMRB-11	B, C, R, S	BD = 090° front	HMRB11BBD...	56565FIL	56570FIL	56579FIL
		DD = 270° back	HMRB11BDD...			
	B, C	AP, AD = 000° up	HMRB11BAP...	56566FIL		
	B, C	CP, CD = 180° down	HMRB11BCP...			
	R, S	AP, AD = 000° up	HMRB11RAP...	56559FIL	56582FIL	
R, S	CP, CD = 180° down	HMRB11RCP...				
HMRB-15	B, C, R, S	BD = 090° front	HMRB15BBD...	56412FIL	15227FIL	56423FIL
		DD = 270° back	HMRB15BDD...			
	B, C	AP, AD = 000° up	HMRB15BAP...	50353FIL		
	B, C	CP, CD = 180° down	HMRB15BCP...			
	R, S	AP, AD = 000° up	HMRB15RAP...	56412FIL		
R, S	CP, CD = 180° down	HMRB15RCP...				
HMRB-18	B, C, R, S	BD = 090° front	HMRB18BBD...	56413FIL	56419FIL	56425FIL
		DD = 270° back	HMRB18BDD...			
	B, C	AP, AD = 000° up	HMRB18BAP...	50655FIL		
	B, C	CP, CD = 180° down	HMRB18BCP...			
	R, S	AP, AD = 000° up	HMRB18RAP...	56413FIL		
R, S	CP, CD = 180° down	HMRB18RCP...				
HMRB-24	B, C, R, S	BD = 090° front	HMRB24BBD...	56414FIL	56416FIL	56427FIL
		DD = 270° back	HMRB24BDD...			
	B, C	AP, AD = 000° up	HMRB24BAP...	56415FIL		
	B, C	CP, CD = 180° down	HMRB24BCP...			
	R, S	AP, AD = 000° up	HMRB24RAP...	56414FIL		
R, S	CP, CD = 180° down	HMRB24RCP...				



Gear	Mounting kit	Servo motor	Motor cable	Resolver cable	Controller	Connector kit
LP050		SMH60 60 1.4 8 11 S 2ID 65 4	MOK54/03	REK41/03	C3S 015 V4 F10 I11 T11 M00	ZBH02/02
LP050		SMH82 60 03 8 14 S 2ID 65 4	MOK54/03	REK41/03	C3S 038 V4 F10 I11 T11 M00	
LP050		SMH60 60 1.4 8 11 S 2ID 65 4	MOK54/03	REK41/03	C3S 015 V4 F10 I11 T11 M00	ZBH02/02
LP070		SMH82 60 03 8 14 S 2ID 65 4	MOK54/03	REK41/03	C3S 038 V4 F10 I11 T11 M00	
PS60-xxx-S2 RS60-xxx-S2	MU60-254	SMH60 60 1.4 8 11 S 2ID 65 4	MOK54/03	REK41/03	C3S 015 V4 F10 I11 T11 M00	ZBH02/02
PS60-xxx-S2 RS60-xxx-S2	MU60-321	SMH82 60 03 8 14 S 2ID 65 4	MOK54/03	REK41/03	C3S 038 V4 F10 I11 T11 M00	
PS90-xxx-S2 RS90-xxx-S2	MU90-001	SMH82 60 03 8 14 S 2ID 65 4	MOK54/03	REK41/03	C3S 038 V4 F10 I11 T11 M00	ZBH02/02
PS90-xxx-S2 RS90-xxx-S2	MU90-088	SMH100 56 06 5 19 S 2ID 65 4	MOK54/03	REK41/03	C3S 075 V4 F10 I11 T11 M00	
PS115-xxx-S2 RS115-xxx-S2	MU115-270	SMH100 56 06 5 19 S 2ID 65 4	MOK54/03	REK41/03	C3S 075 V4 F10 I11 T11 M00	ZBH02/02
PS115-xxx-S2 RS115-xxx-S2	MU115-026	SMH115 56 10 5 24 S 2I 65 4	MOK57/03	REK41/03	C3S 150 V4 F10 I11 T11 M00	

Information:

The SMH motors can be also equipped with an absolut multturn encoder and/or holding brake for vertical applications. Shown cables are with 5 meter cable length. Other lengths on request.



EMAC s.r.o.
Kasarenska 2404/26
911 05 Trencin
SLOVAKIA

Parker certified distributor
☎ +421 32 3810 232
✉ info@emac.sk
🌐 www.emac.sk