



AC20 Series

PROFIBUS– Communication Option

Technical Manual

DOC-0017-09-EN-B
04.04.2023



ENGINEERING **YOUR** SUCCESS.

1 Safety

IMPORTANT: Please read this information BEFORE installing the equipment.

1.1 Intended Users

This manual is to be made available to all persons who are required to install, configure or service equipment described herein, or any other associated operation.

The information given is intended to highlight safety issues, and to enable the user to obtain maximum benefit from the equipment.

Complete the following table for future reference detailing how the unit is to be installed and used.

INSTALLATION DETAILS	
Model Number (see product label)	
Where installed (for your own information)	

1.2 Application Area





The equipment described is intended for industrial motor speed control utilizing AC induction motors or AC permanent magnet synchronous machines.

1.3 Personnel

Installation, operation, and maintenance of the equipment should be carried out by competent personnel. A competent person is someone that is technically qualified and familiar with all safety information and established safety practices; with the installation process, operation, and maintenance of this equipment, and with all the hazards involved.

1.4 Product Warnings

Special attention must be paid to the information presented in warning, caution, and information notices when they appear in this manual. Definitions of caution, warning and information notices are shown below:

 DANGER Risk of electric shock	 WARNING Hot surfaces	 Caution Refer to documentation	 Earth/Ground Protective Conductor Terminal
---	--	--	--

Application Risk

The specifications, processes and circuitry described herein are for guidance only and may need to be adapted to the user's specific application. We cannot guarantee the suitability of the equipment described in this Manual for individual applications.

Risk Assessment

Under fault conditions, power loss or unintended operating conditions, the drive may not operate as intended. In particular:



- Stored energy might not discharge to safe levels as quickly as suggested and can still be present even though the drive appears to be switched off.
- The motor's direction of rotation might not be controlled
- The motor speed might not be controlled
- The motor might be energised

A drive is a component within a drive system that may influence its operation or effects under a fault condition. Consideration must be given to:

- Stored energy
- Supply disconnects
- Sequencing logic
- Unintended operation



1.5 Safety Information



Risk of Electric Shock

	DANGER!	
	Ignoring the following may result in injury:	
	<ul style="list-style-type: none"> - This equipment can endanger life by exposure to rotating machinery and high voltages. - The equipment must be permanently earthed due to the high earth leakage current, and the inverter motor must be connected to an appropriate safety earth. - Ensure all incoming supplies are isolated before working on the equipment. Be aware that there may be more than one supply connection to the inverter. - There may still be dangerous voltages present at power terminals (motor output, supply input phases, DC bus and the brake, where fitted) when the motor is at standstill or is stopped. - For measurements use only a meter to IEC 61010 (CAT III or higher). Always begin using the highest range. CAT I and CAT II meters must not be used on this product. - Allow at least 5 minutes for the inverter's capacitors to discharge to safe voltage levels (<50V). Use the specified meter capable of measuring up to 1000V dc & ac rms to confirm that less than 50V is present between all power terminals and between power terminals and earth. - Unless otherwise stated, this product must NOT be dismantled. In the event of a fault the inverter must be returned. Refer to "Routine Maintenance and Repair". 	

Safety & EMC Requirements

Where there is a conflict between safety and EMC requirements, personnel safety shall always take precedence.

	WARNING! Ignoring the following may result in injury or damage to equipment:	
	<ul style="list-style-type: none">- Never perform high voltage resistance checks on the wiring without first disconnecting the inverter from the circuit being tested.- Whilst ensuring ventilation is sufficient, provide guarding and /or additional safety systems to prevent injury or damage to equipment.- When replacing an inverter in an application and before returning to use, it is essential that all user defined parameters for the product's operation are correctly installed.- When replacing an inverter in an application and before returning to use, it is essential that all user defined parameters for the product's operation are correctly installed.- All control and signal terminals are SELV, i.e. protected by double insulation. Ensure all external wiring is rated for the highest system voltage.- Thermal sensors contained within the motor must have at least basic insulation.- All exposed metalwork in the Inverter is protected by basic insulation and bonded to a safety earth.- RCDs are not recommended for use with this product but, where their use is mandatory, only Type B RCDs should be used.	

	WARNING! Ignoring the following may result in injury or damage to equipment:	
	<ul style="list-style-type: none">- In a domestic environment this product may cause radio interference in which case supplementary mitigation measures may be required.- This equipment contains electrostatic discharge (ESD) sensitive parts. Observe static control precautions when handling, installing and servicing this product.- This is a product of the restricted sales distribution class according to IEC 61800-3. It is designated as "professional equipment" as defined in EN61000-3-2 for. Permission of the supply authority shall be obtained before connection to the public low voltage supply.	

2 Manufacturing Location

Germany

Parker Hannifin Manufacturing Germany GmbH & Co. KG

Electric Motion & Pneumatic Division (EMPD)

Robert-Bosch-Strasse 22

77656 Offenburg (Germany)

Tel.: + 49 (0781) 509-0

Website: www.parker.com/eme

Certified according to ISO 9001:2015

Parker Hannifin Manufacturing Germany GmbH & Co. KG - Sitz: Bielefeld - Amtsgericht: Bielefeld HRA 15699
persönlich haftende Gesellschafterin: Parker Hannifin GmbH - Sitz: Bielefeld - Amtsgericht Bielefeld HRB 35489
Geschäftsführung der Parker Hannifin GmbH: Ulrich Jochem, Achim Kohler, Andreas Paulsen, Kirsten Stenvers
Vorsitzender des Aufsichtsrates: Dr.-Ing. Gerd Scheffel

3 Waste Electrical and Electronic Equipment (WEEE)



Waste Electrical and Electronic Equipment - must not be disposed of with domestic waste. It must be separately collected according to local legislation and applicable laws.

Parker Hannifin Company, together with local distributors and in accordance with EU directive 2002/96/EC, undertakes to withdraw and dispose of its products, fully respecting environmental considerations. For more information about how to recycle your Parker supplied waste equipment, please contact your local Parker Service Centre.

Packaging

During transport our products are protected by suitable packaging. This should be taken for central disposal as secondary raw material.

4 Table of Contents

1	Safety	2
1.1	Intended Users.....	2
1.2	Application Area.....	2
1.3	Personnel.....	2
1.4	Product Warnings.....	2
1.5	Safety Information.....	3
2	Manufacturing Location	5
3	Waste Electrical and Electronic Equipment (WEEE)	6
4	Table of Contents	7
5	Introduction	8
5.1	Product Features.....	8
6	Installation	9
6.1	Order Codes.....	9
6.2	Fitting the Option.....	10
7	Network	13
7.1	Network Connector and Cable Specification.....	13
7.2	LED Indications.....	14
8	Configuration	15
8.1	Communication parameters.....	15
8.2	Process Data.....	18
8.3	Acyclic Data Exchange.....	21
8.4	Profibus GSD File.....	22
9	Example Configuration and Programming	23
9.1	AC20 Motor Control Application.....	23
9.2	List of process data.....	24
9.3	Programming with Siemens PLC.....	25
10	Lost Communication Trip	34
11	Diagnostic Event	35
	APPENDIX A: Data types	36
	APPENDIX B: Parameters	37
	APPENDIX C: DSE Lite Quick Start Guide	40

5 Introduction

5.1 Product Features

- Supports PROFIBUS DP-V1 functionality.
- Automatic baud rate detection.
- Generic and Profibus specific diagnostic support.
- User parameterization data support.
- Set Slave Address Support.
- Acyclic data access via DP-V1 read/write services.
- Maximum 244 bytes of process input data and 244 bytes of process output data.
- GSD file provided.
- Status and Operation Mode LEDs.
- 1x 9-pin D-SUB female connector to Profibus.



6 Installation

DANGER!

RISK OF ELECTRIC SHOCK



Terminal covers, main covers, and cover fixings must remain in place while the drive is energized.

These should only be removed once the supply to the unit and/or system has been disconnected, and the residual energy in the DC link capacitors has been discharged.



CAUTION!

ESD SENSITIVE EQUIPMENT



Take ESD precautions when handling the Communication Interface Option Cards to avoid any risk of damaging the equipment.



- All activities covered in this chapter should be carried out when there is no power to the inverter.
- If the drive has been powered up, ensure enough time has elapsed that the inverter has discharged its residual energy.
- Always check that the voltages on the user terminals are at a safe level (<50V) before carrying out any of these activities.

6.1 Order Codes

Order Code	Description
2003-CB-00	CANopen communication interface option card
2003-EC-00	EtherCAT communication interface option card
2003-IP-00	Ethernet IP communication interface option card
2003-PB-00	Profibus DP-V1 communication interface option card
2003-PN-00	PROFINET IO communication interface option card
2003-RS-00	RS485 Modbus RTU communication interface option card

6.2 Fitting the Option

Frames 2 – 5

The Communication Interface Option Cards are intended to be customer installed. The control module housing cover will need to be removed prior to option card installation.

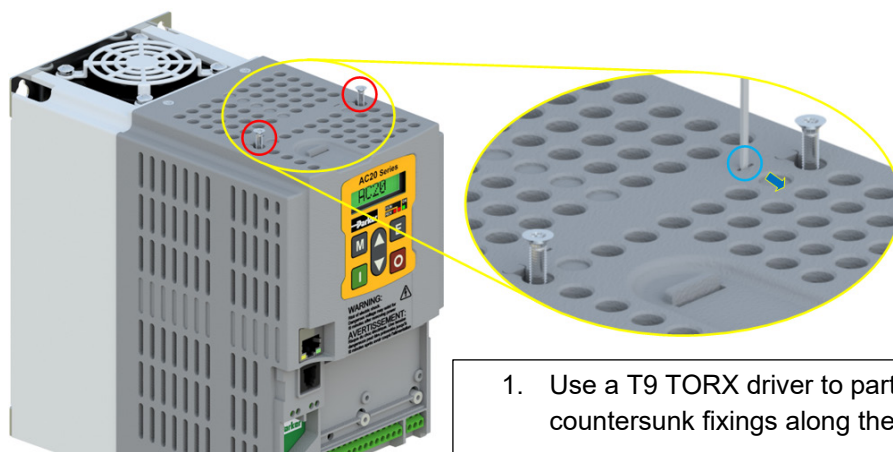

1. Use a T9 TORX driver to partially unscrew the two 3x12 countersunk fixings along the top of the product.
2. Insert a flat head screwdriver into the moulding features and lever the control module housing away from the power

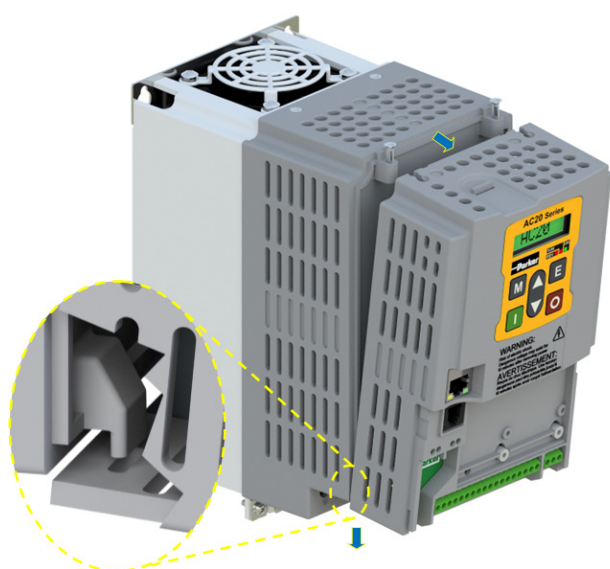

3. Unhook the bottom of the control module housing from the power stack.
4. Gently turn the control module upside down so it rests to the right of the power stack, with the interface cables still connected.

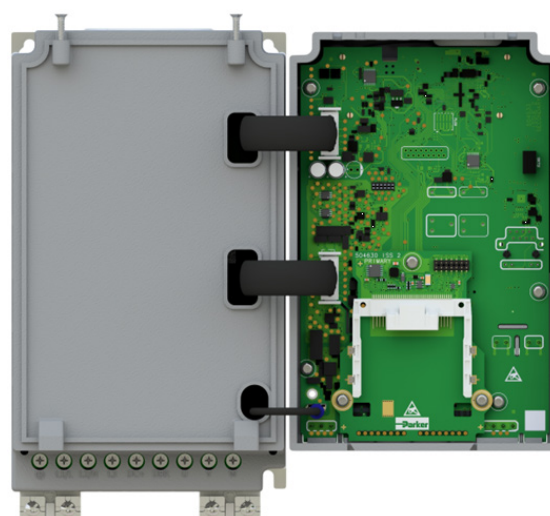

5. Remove and discard the Comms Option break-out feature in the control module housing by cutting the 7x bridges using suitable small side cutters.

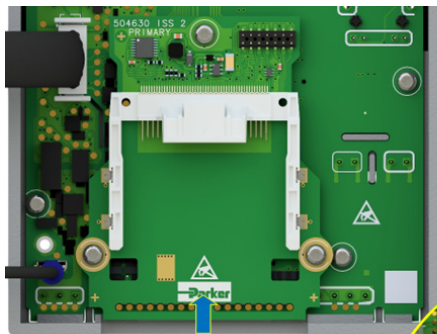
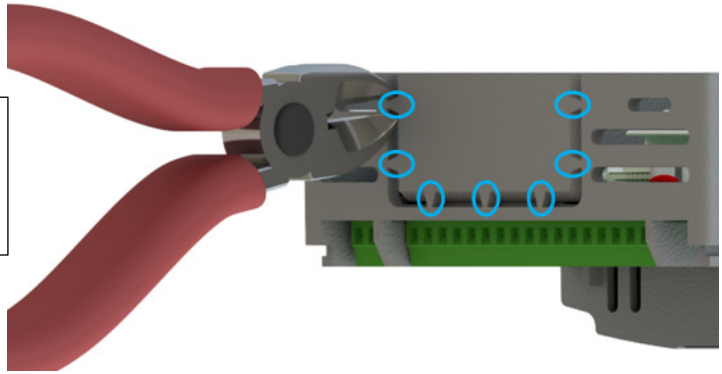

6. Remove the Comms Interface Option card from its packaging.

7. Slide the Comms Card along the PCB using the connector features for alignment.

Note: The front facia of the Option should be loose at this point.

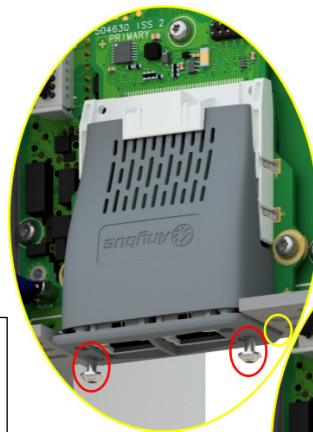
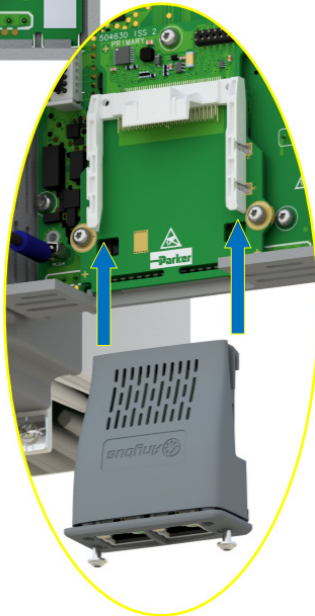

9. Now fully tighten the two T8 screws on the front facia of the Communication Interface Option Card.
10. Check that the Option Card is secure and that it cannot slide out.
11. Reassemble the product by performing the reverse process of steps 1 – 4.



In the event that the Communication Interface Option Card needs to be removed, follow the installation process, but perform steps 7 and 8 in reverse.

Frame 6 – 10

On Frames 6 – 10, the lower terminal cover will need to be removed prior to option card installation.

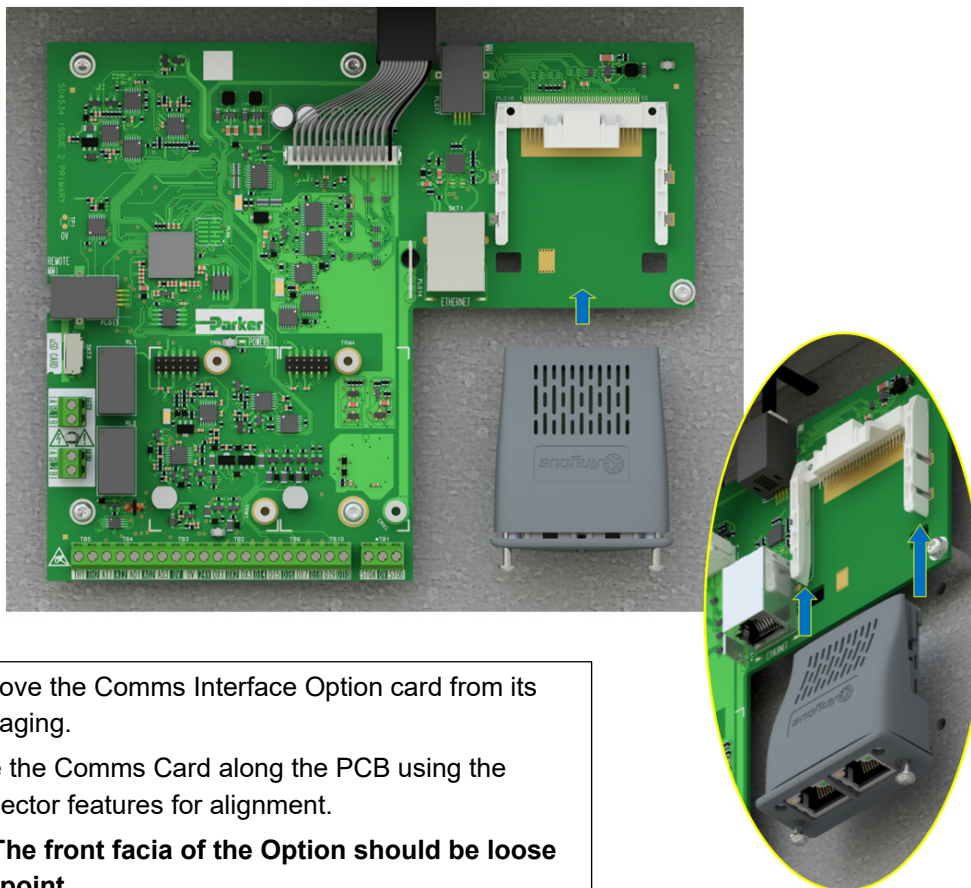

1. Remove the Comms Interface Option card from its packaging.
2. Slide the Comms Card along the PCB using the connector features for alignment.

Note: The front facia of the Option should be loose at this point.

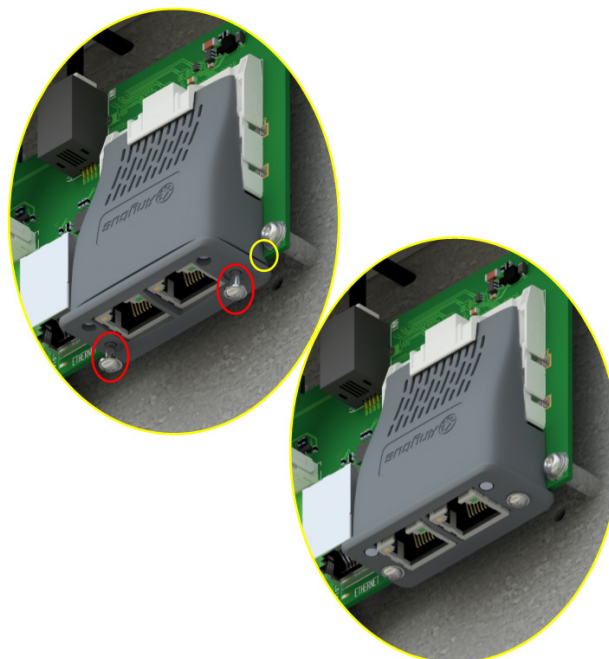

3. When the Comms Interface Option Card is fully engaged in the connector and its housing has hocked onto the edge of the PCB, fully tighten the two T8 screws on the front facia.
4. Check that the Option Card is secure and that it cannot slide out.

In the event that the Communication Interface Option Card needs to be removed, perform steps 2 & 3 in reverse.

7 Network

7.1 Network Connector and Cable Specification

Profibus DP-V1 Connectors

Only use connectors recommended by Profibus. The connector will have a shield clamp providing shield continuity and will help to ensure good noise immunity of your network.

Pin	Signal	Description
1	-	-
2	-	-
3	B Line	Positive RxD/TxD, RS485 level
4	RTS	Request to send
5	GND Bus	Ground (isolated)
6	+5 V Bus Output	+5 V termination power (isolated, short-circuit protected)
7	-	-
8	A Line	Negative RxD/TxD, RS485 level
9	-	-
Housing	Cable Shield	Connected to protective earth via filter

Cable Specification

PROFIBUS DP-V1 cable uses a specific color code (red/green). You should maintain this color code throughout your network. The cable has a single twisted pair with overall shielding. The bus line is specified in IEC 61158 and it can be used in accordance with the table below.

Cable Parameters	PROFIBUS line
Surge impedance in Ω	135 ... 165
Capacitance per unit length (pF/m)	< 30
Loop resistance (Ω /km)	110
Core diameter (mm)	0.64

- Failure to terminate a network correctly can reduce the noise immunity of the network and affect performance.
- A termination resistor must be fitted at each end of the network to prevent interference.
- If too many resistors are fitted to the network, the resulting reduced signal levels may cause nodes to miss bits of information. If network overload becomes excessive, the reduced signal levels may prevent the nodes from detecting any activity.
- Connect terminating resistors to the end drives as shown below. (All resistors $\pm 5\%$, minimum $\frac{1}{4}$ Watt).

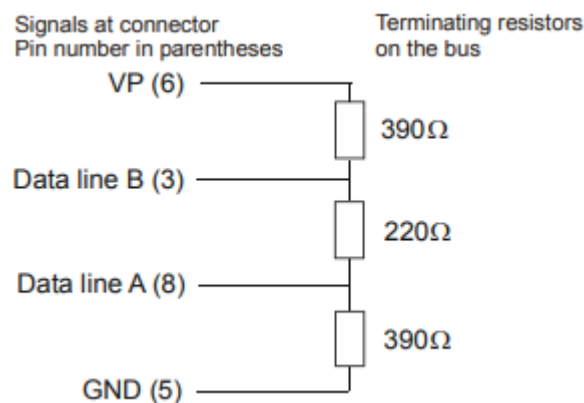

The maximum number of nodes allowed on a single PROFIBUS DP-V1 network segment is 32. A repeater can be used to extend the network length and/or to allow more than 32 nodes to be connected.

Wiring Diagram Example

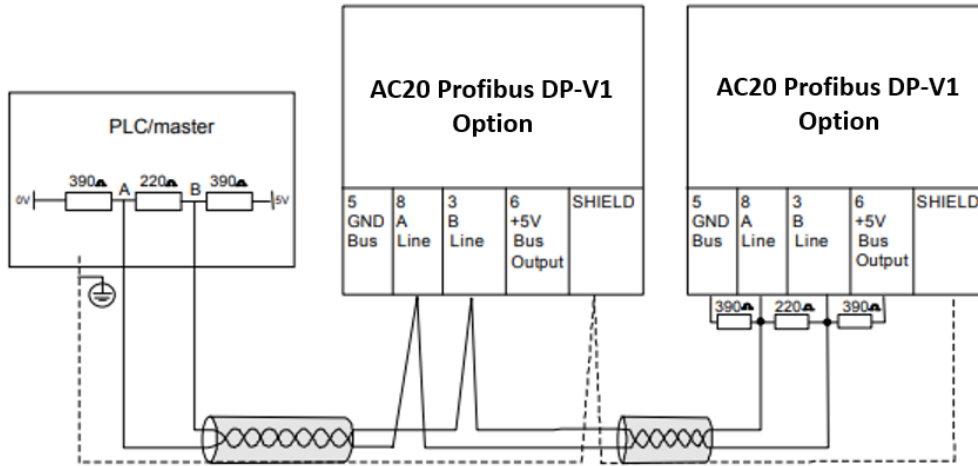

7.2 LED Indications



Operation (OP) LED

LED State	Indication
Off	Not online / No power
Green	Online, data exchange
Flashing Green	Online, clear
Flashing Red (1 flash)	Parameterization error
Flashing Red (2 flash)	Configuration error

Status (ST) LED

LED State	Indication	Comments
Off	Not Initialized	No power or Module in SETUP or NW_INIT state.
Green	Initialized	Module has shifted from the NW_INIT state
Flashing Green	Initialized, diagnostic event(s) present	Extended Diagnostic bit set
Red	Exception error	Device in state Exception.
Red	Bus off (Fatal Event)	Bus off

8 Configuration

The option comms configuration is accessible through the keypad under the menu **Option Comms**, through DSE Lite function block **Option Comms Config** or through the webserver following the path **Home > Engineer > Communications > Option Comms**.

The AC20 CANopen option requires configuration of both communication parameters and process data mapping.

8.1 Communication parameters

Keypad Menu Path	DSE-Lite Function Block	Webserver
<pre> graph TD Setup[Setup] --> Communication[Communication] Communication --> Option[Option] </pre>	<pre> Option Comms Config COMMS FITTED NONE COMMS VERSION(0) 0 COMMS VERSION(1) 0 COMMS SERIAL NUM 0x00000000 COMMS STATE NONE DIAGNOSTIC OK EXCEPTION CODE 0x0000 COMMS SUPERVISED FALSE MAPPING CHANGED FALSE STATION NAME IP ADDRESS 0.0.0.0 SUBNET MASK 0.0.0.0 GATEWAY ADDRESS 0.0.0.0 ACTUAL BAUD RATE AUTO NONE EXTERNAL 0.0.0.0 0.0.0.0 0.0.0.0 0x001E 0 AUTO 19200 BPS EVEN 1 STOP FALSE 0 TRUE COMMS REQUIRED ADDR ASSIGNMENT SET IP ADDRESS SET SUBNET MASK SET GATEWAY ADDR ACCESS NODE ADDRESS CANOPEN BAUD MODBUS BAUD RATE PARITY HIGH WORD FIRST ACTIVE TIMEOUT MASTERMAPPING </pre>	<pre> Home > Engineer > Communications > Option Comms 0691: Comms Required NONE 0769: Comms Fitted UNKNOWN 0770: Comms Version + 0773: Comms Serial Num 00000000 0774: Comms State NONE 0775: Diagnostic OK 0776: Exception Code 0000 </pre>

The network parameters of the slave must be set to establish communication with master.

- The parameter **0691 COMMS REQUIRED** must be set to **PROFIBUS**.
The parameter **0763 NODE ADDRESS** must be set to the required address of the AC20 Profibus slave. The module address must be unique to be able to communicate on the Profibus network. The valid setting range is from **0 to 125**. If the address is set to 126 then the SSA (Set Slave Address) will be used, which enables a master or configuration tool to set the node address from network.
- The parameter **2566 MASTERMAPPING** must be set to choose how process data mapping is defined. (See 8.2 Process Data for detail)

Configuration with DSE Lite

When performing an online configuration, the fitted option card will automatically be selected. In offline mode, display your configuration page in DSE Lite and click the plus sign [+] at the left of function block **Option Comms Config** to see set communication parameters.

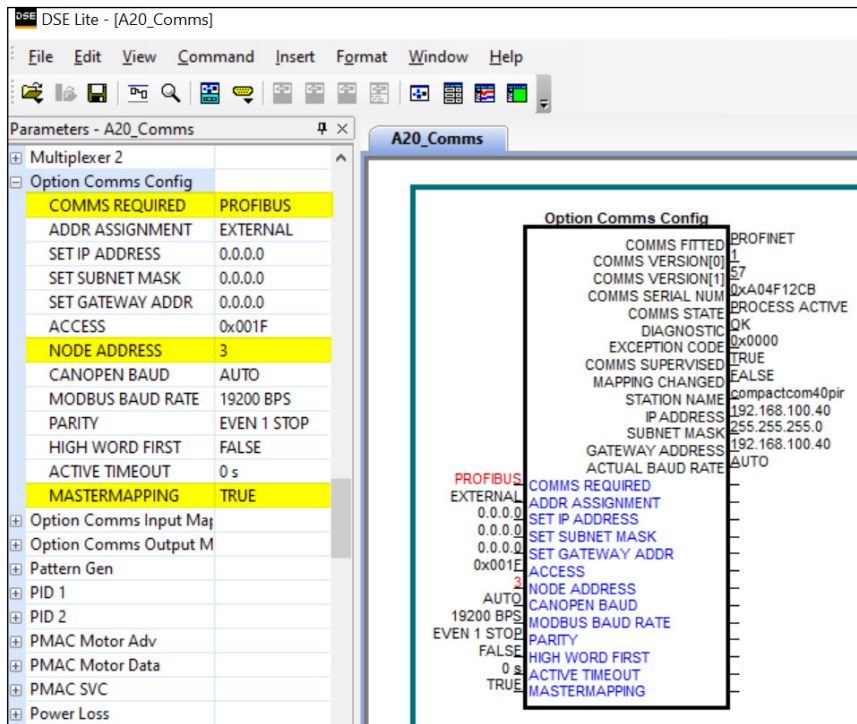

Alternatively, perform the steps described above by double clicking on the function block **Option comms config** to open parameters tab in the configuration interface.

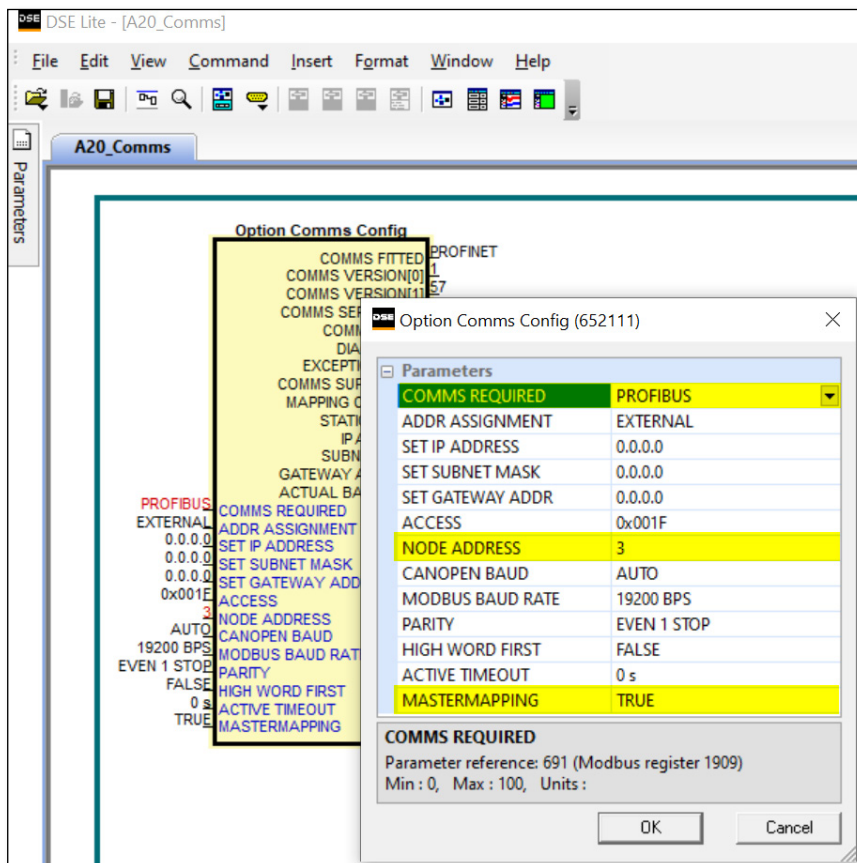

Configuration with the webserver

Access the AC20 webserver by typing the IP-Address of the drive into the web browser.

The drive must be in configuration state. Set the CAN Option comms parameters as shown below.

AC20 Webserver view when Master mapping is TRUE

The screenshot shows the Parker AC20 webserver interface. At the top, there is a navigation bar with 'Summary', 'Parameters', and 'Passwords'. Below this, a breadcrumb trail reads 'Home > Engineer > Communications > Option Comms'. On the left side, there is a user dropdown menu set to 'ENGINEER', a 'Monitor' button, and a 'State: Configuration' indicator. The main content area displays several parameters: '0691: Comms Required' is set to 'PROFIBUS'; '2566: MasterMapping' is checked with a checkbox; '0763: Node Address' is set to '3'; and '0769: Comms Fitted' is 'UNKNOWN'. The 'Drive: OK' status is shown in green.

AC20 Webserver view when Master mapping is FALSE

The screenshot shows the Parker AC20 webserver interface with 'MasterMapping' set to FALSE. The layout is identical to the previous screenshot, but the '2566: MasterMapping' checkbox is unchecked. The 'State: Configuration' indicator is present, and the 'Drive: OK' status is shown in green.

8.2 Process Data

The AC20 Profibus option requires configuration of **process data mapping**.

Config Mapping

There are two methods to define process data mapping: The process data can be mapped using the AC20 input and output mapping tables or from the PLC.

The parameter **2566 MASTERMAPPING** defines the method: If FALSE the AC20 input and output mapping tables will be used to configure process data mapping. If TRUE, the bus master set/configures the Process data mapping and AC20 input and output mapping tables will be cleared.

Note: For parameter 2566 MASTERMAPPING = 'FALSE': If the AC20 mapping tables are both set to zeros or AC20 mapping tables differs from PLC mapping then the option will be mapped from the PLC.

Set process data using AC20 input and output mapping tables

These tables are two parameter arrays in which AC20 parameter numbers may be added. The parameter **2566 MASTERMAPPING** must be set to **FALSE**.

Read Mapping:

The read process data represents cyclic data sent from the PLC to the AC20, this is mapped into the table **Option Comms Input Mapping**. Only writable AC20 parameters that are not configuration parameters may be added to the read process data.



Keypad Menu Path	DSE Lite Function Block	Webserver
<pre> graph TD Engineer --> Communications Communications --> OptionComms[Option Comms] OptionComms --> InputMapping[Input Mapping[]] </pre>	<pre> Option Comms Input Mapping MAPPING[0] MAPPING[1] MAPPING[2] MAPPING[3] MAPPING[4] MAPPING[5] MAPPING[6] MAPPING[7] MAPPING[8] MAPPING[9] MAPPING[10] MAPPING[11] MAPPING[12] MAPPING[13] MAPPING[14] MAPPING[15] MAPPING[16] MAPPING[17] MAPPING[18] MAPPING[19] MAPPING[20] MAPPING[21] MAPPING[22] MAPPING[23] MAPPING[24] MAPPING[25] MAPPING[26] MAPPING[27] MAPPING[28] MAPPING[29] MAPPING[30] MAPPING[31] </pre>	<pre> Home > Engineer > Communications > Option Comms 0691: Comms Required [PROFIBUS] 2566: MasterMapping [] 0692: Input Mapping - 000: [0000] 001: [0000] 002: [0000] 003: [0000] 004: [0000] 005: [0000] 006: [0000] 007: [0000] 008: [0000] 009: [0000] 010: [0000] </pre>

Write Mapping:

The write process data represents cyclic data sent from the AC20 to the PLC, this is mapped into the table **Option Comms Output Mapping**.



Keypad Menu Path	DSE Lite Function Block	Webserver
	<p>Option Comms Output Mapping</p> <p>MAPPING[0] MAPPING[1] MAPPING[2] MAPPING[3] MAPPING[4] MAPPING[5] MAPPING[6] MAPPING[7] MAPPING[8] MAPPING[9] MAPPING[10] MAPPING[11] MAPPING[12] MAPPING[13] MAPPING[14] MAPPING[15] MAPPING[16] MAPPING[17] MAPPING[18] MAPPING[19] MAPPING[20] MAPPING[21] MAPPING[22] MAPPING[23] MAPPING[24] MAPPING[25] MAPPING[26] MAPPING[27] MAPPING[28] MAPPING[29] MAPPING[30] MAPPING[31]</p>	

Note: *String-type parameters cannot be mapped.*

Set process data from Profibus master

The GSD file defines the modules. Each module corresponds to an AC20 parameter, when configuring the PLC, the modules may be added to the slave device slots as required. These modules map to the process data in the order in which they are added.

The parameter **2566 MASTERMAPPING** must be set to **TRUE** and this will auto reset any AC20 input and output mapping inside the drive.

Cyclic Data Exchange

Cyclic data exchange will occur when an MS0 connection is established, i.e. when the Profibus State is IDLE (master mode = clear) or PROCESS ACTIVE (master mode = operate).

However, the read process data will only update the mapped parameters when in the PROCESS ACTIVE state. On a transition into the PROCESS ACTIVE state all read process mapped parameters will be updated.

When in the PROCESS ACTIVE state the read process mapped parameters will all update only when a change in the read process data occurs.

Mapping status

The process data mapping status can be accessed from AC20 via the following parameters:

- Parameter **2586 InMappingStatus**: shows the status of the currently active cyclic data input mapping table (32 entries), value is the Tag ID of the parameter to be cyclic read in.
- Parameters **2619 OutMappingStatus**: Shows the status of the currently active cyclic data output mapping table (32 entries), value is the Tag ID of the parameter to be cyclic sent out.

The parameters **2586 InMappingStatus** and **2619 OutMappingStatus** are visible from webserver if Parameter **2566 MasterMapping = TRUE** and are valid if **Parameter 0774 Comms State = PROCESS ACTIVE**.

The screenshot shows the Parker AC20 webserver interface. At the top left is the Parker logo. Below it are navigation tabs: Summary | Parameters | Passwords. A breadcrumb trail reads: Home ► Engineer ► Communications ► Option Comms. On the left, there is a user dropdown menu set to 'ENGINEER', a 'Monitor' button, and status indicators: 'State: Operational' and 'Drive: Stopped'. The main area displays a list of parameters: 0691: Comms Required (set to PROFIBUS), 2566: MasterMapping (checked), 2586: InMappingStatus + (highlighted in yellow), 2619: OutMappingStatus + (highlighted in yellow), 0763: Node Address (set to 3), and 0769: Comms Fitted (set to PROFIBUS).

8.3 Acyclic Data Exchange

AC20 parameters may be accessed acyclically from the network using Record Data read / write services. There is a 1:1 correlation between the index and the parameter number.

The parameter length in the DP-V1 request specifies the number of bytes to read/write.

- When reading more data than the actual size of the parameter, the response will only contain the actual parameter data without any additional padding.
- When reading less data than the actual size of the parameter, only the requested amount of data is returned by the module.
- The maximum parameter data size that can be accessed is 240 bytes for acyclic DP-V1 read/write and 234 bytes for acyclic read/writes using the call service.
- When writing to a parameter, the length parameter is not checked by the module, i.e. the host application must respond with an error if the length differs from the actual size of the requested parameter.

Parameter Read with Call Handling

The Parameter Read with **Call Service** request is as follows:

Byte #	Contents	Field name	Value	Notes
1	DP-V1	Function no	5Fh	Write service
2	Header	Slot	00h	must not be set to FFh
3		Index	FFh	Fixed
4		Length of telegram	06h	Call header + Parameter no.
5		Call	External Function no.	08h
6	Header	(reserved)	00h	Reserved, set to zero
7		Subindex High Byte	00h	Fixed value used when reading
8		Subindex Low Byte	02h	
9	Parameter number	High Byte	0000h...	Number of the parameter which shall be read
10		Low Byte	FFFFh	

Upon reception, the module translates this into a read request, the response will be transformed into an appropriate response telegram on Profibus as follows:

Parameter Read with **Call Response**:

Byte #	Contents	Field name	Value	Notes
1	DP-V1	Function no	5Eh	Read service
2	Header	Slot	00h	must not be set to FFh
3		Index	FFh	Fixed
4		Length of telegram	06...F0h	Call header + Parameter no. +Data
5		Call	External Function no.	08h
6	Header	(reserved)	00h	Reserved, set to zero
7		Subindex High Byte	00h	Fixed value used when reading
8		Subindex Low Byte	02h	
9	Parameter number	High Byte	0000h...	Number of the parameter which shall be read
10		Low Byte	FFFFh	
11...n	Data	(actual Data)	-	Data returned (max value of n = 244)

Parameter Write with Call Handling

The parameter write with **Call Service request** looks as follows:

Byte #	Contents	Field name	Value	Notes
1	DP-V1 Header	Function no	5Fh	Write service
2		Slot	00h	must not be set to FFh
3		Index	FFh	Fixed
4		Length of telegram	06...F0h	Call header + Parameter no. +Data
5	Call Header	External Function no.	08h	Call service
6		(reserved)	00h	Reserved, set to zero
7		Subindex High Byte	00h	Fixed value used when writing
8		Subindex Low Byte	01h	
9	Parameter number	High Byte	0000h...	Number of the parameter which shall be read
10		Low Byte	FFFFh	
11...n	Data	(Actual Data)	-	Data to send (max value of n = 244)

Upon reception, the module translates this into a write request, the response will be transformed into an appropriate response telegram on Profibus as follows:

Parameter Write **Call response**

Byte #	Contents	Field name	Value	Notes
1	DP-V1 Header	Function no	5Eh	Read service
2		Slot	00h	must not be set to FFh
3		Index	FFh	Fixed
4		Length of telegram	06...F0h	Call header + Parameter no.
5	Call Header	External Function no.	08h	Call service
6		(reserved)	00h	Reserved, set to zero
7		Subindex High Byte	00h	Fixed value used when writing
8		Subindex Low Byte	01h	
9	Parameter number	High Byte	0000h...	Number of the parameter which shall be read
10		Low Byte	FFFFh	

8.4 Profibus GSD File

The GSD device description file holds a description of the device and its functions. Most important the file describes the parameters implementation in the module. GSD file for the AC20 Profibus option may be downloaded from www.parker.com

9 Example Configuration and Programming

9.1 AC20 Motor Control Application

Use DSE Lite to create, parameterize and configure user defined applications or parameterize and connect fixed motor control blocks in the application. Download the application into the drive then connect to the PLC to read/write the value of the parameters.

In the example below the PLC is used to set motor speed and control, then to read the speed feedback, status of the control and speed reference.

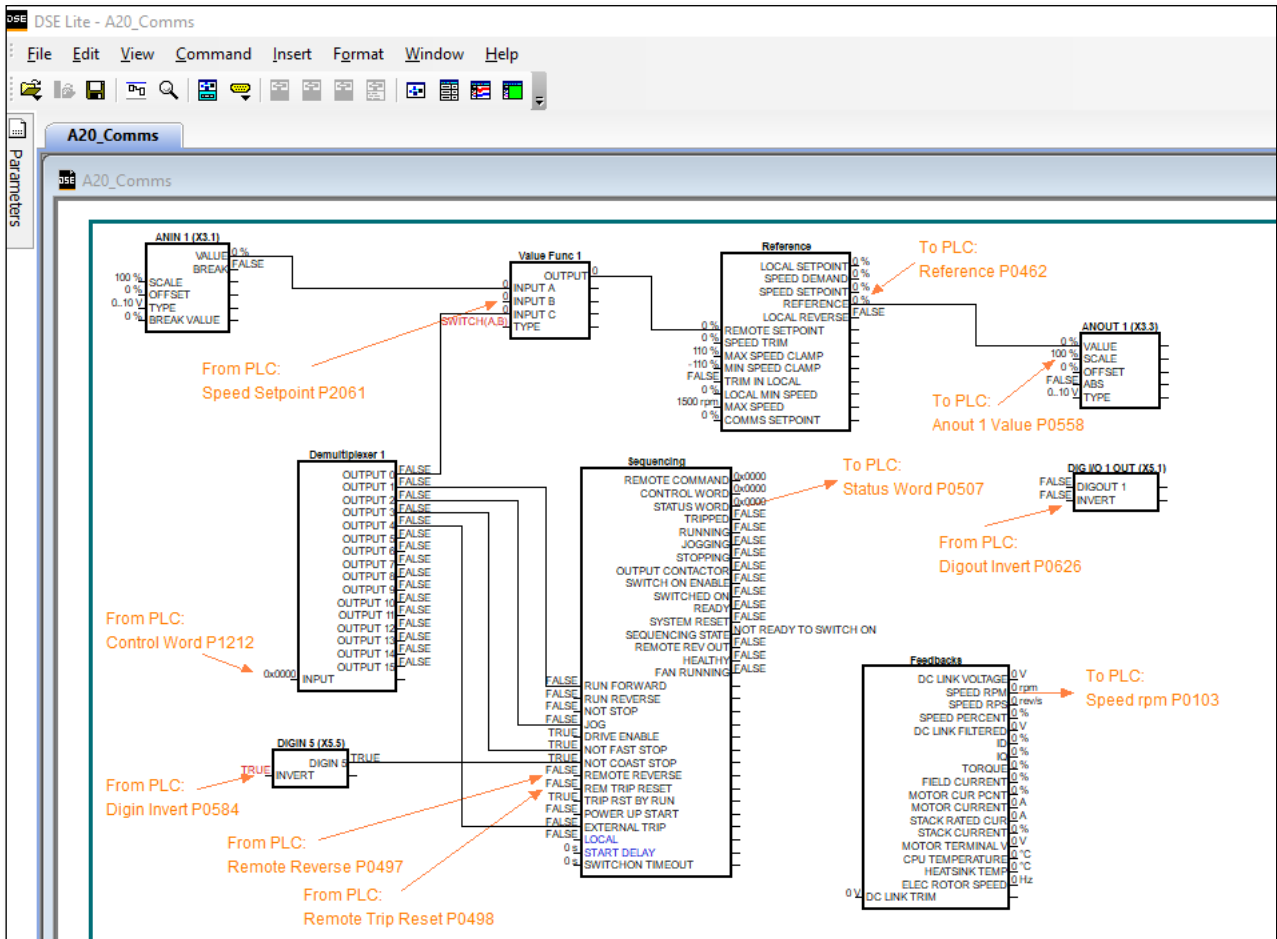

The data highlighted will be mapped into the AC20 process data mapping table in the example below.

9.2 List of process data

Read / Write Process Data mapping list for master/PLC

AC20 Input Mapping	Data Type	Comments	PLC Module
1212 Input Demultiplexer 1	WORD	Control Word	Output
2061 Input B Value Func 1	REAL	Speed Setpoint	
0584 Digin Invert	WORD	Invert digital input	
0626 Digout Invert	WORD	Invert digital Output	
0497 Remote reverse	BOOL	Invert motor Rotation	
0498 Rem Trip Reset	BOOL	Trip Reset	

AC20 Output Mapping	Data Type	Comments	PLC Module
0507 Status Word	WORD	Status Word	Input
0462 Reference	REAL	Speed Reference	
0103 Speed rpm	REAL	Speed Feedback	
0534 Anin1 Value	REAL	Analog In1 Value	
0540 Anin2 Value	REAL	Analog In2 Value	
0558 Anout1 Value	REAL	Analog Out1 Value	
0563 Anout2 Value	REAL	Analog Out2 Value	
0610 Digin Word	WORD	Digital Input state	
0625 Digout Word	WORD	Digital Output state	

9.3 Programming with Siemens PLC

The example uses Siemens CPU 315-2DP as controller PLC and Tia Portal V14 as programming Environment. Prior knowledge of TIA Portal software is assumed.

Create a project

- Launch the Tia portal software from desktop then click **Start** and select **Create new project**. Define project properties and click on **Create**.

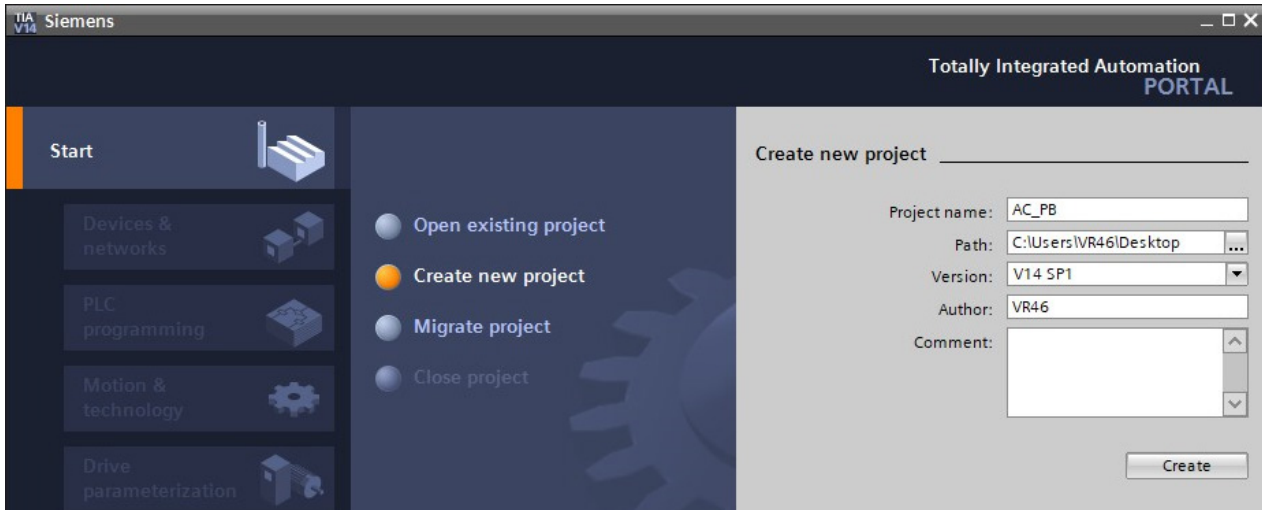

Add Controller (PLC)

- Click on **Devices & networks**, select **Add new device**, select your controller from catalog then click on **Add** to insert the PLC into the project.

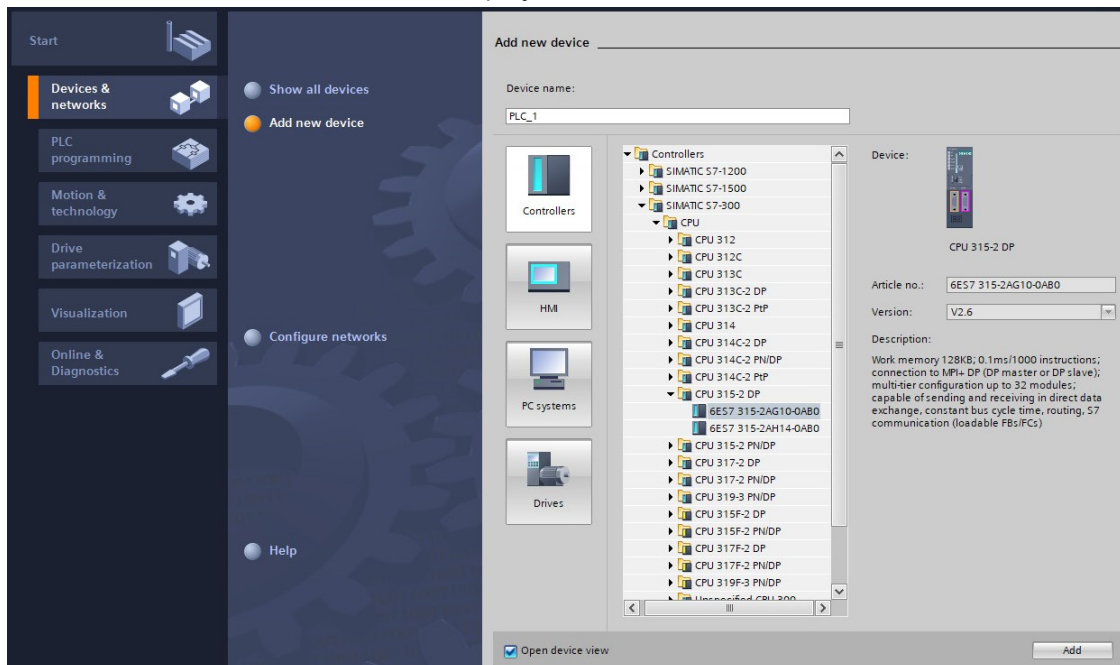

- From the **Devices & Networks** view select the controller, then click on properties to set the **controller network interface**, the **node address** and other parameters.

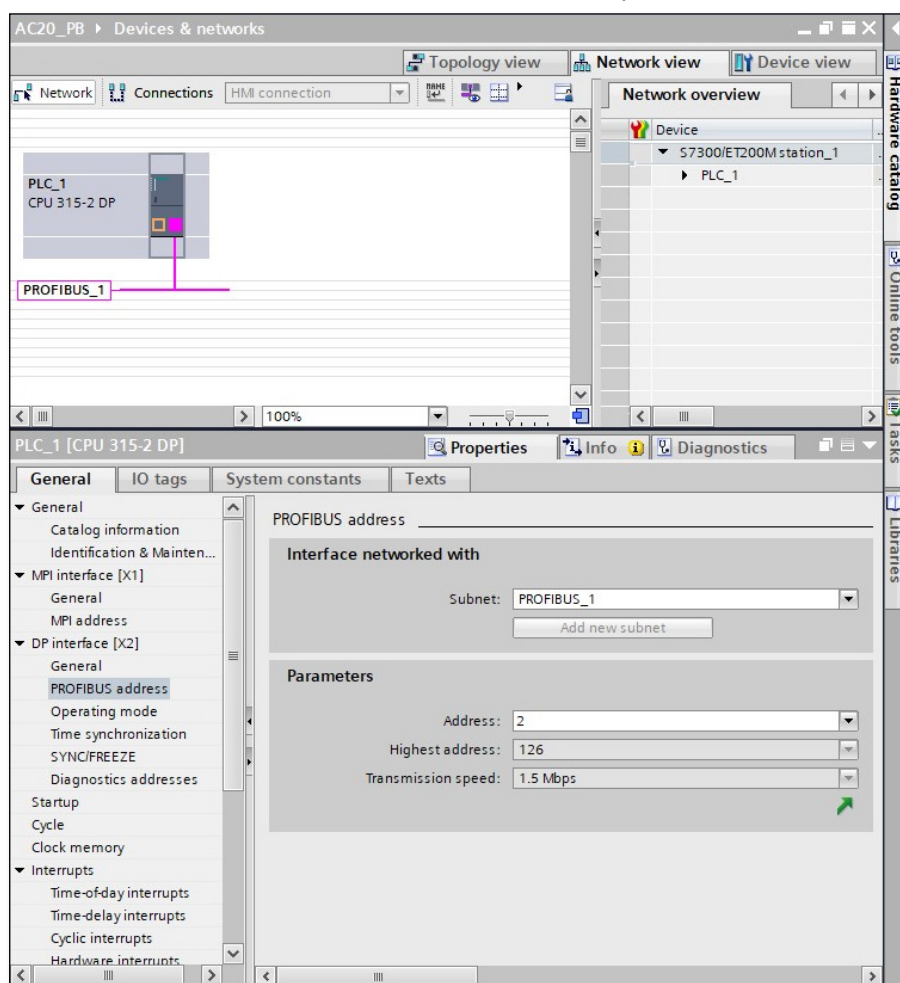

GSD File installation

- From the Tia portal menu bar click on **Options > Manage general station description files (GSD)** to open the tab.

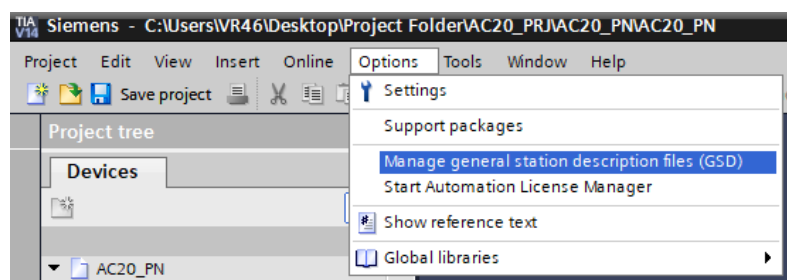

- Click on **source path** to select the folder where the file description is stored.
- Select GSD file then click on **install**.
- The slave will then become available in Tia portal hardware catalogue.

Add AC20 Profibus Slave

- Drag and drop the slave from **Hardware Catalogue** to **Network View**.

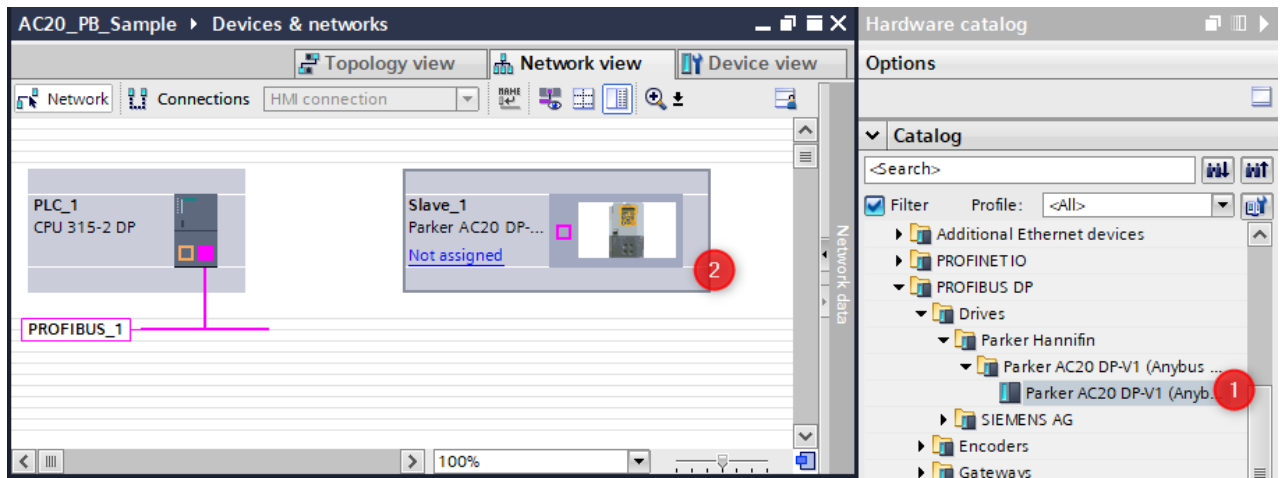

- From the **Devices & network** view select AC20 slave, click on **properties** then select **network interface** to set the node address.

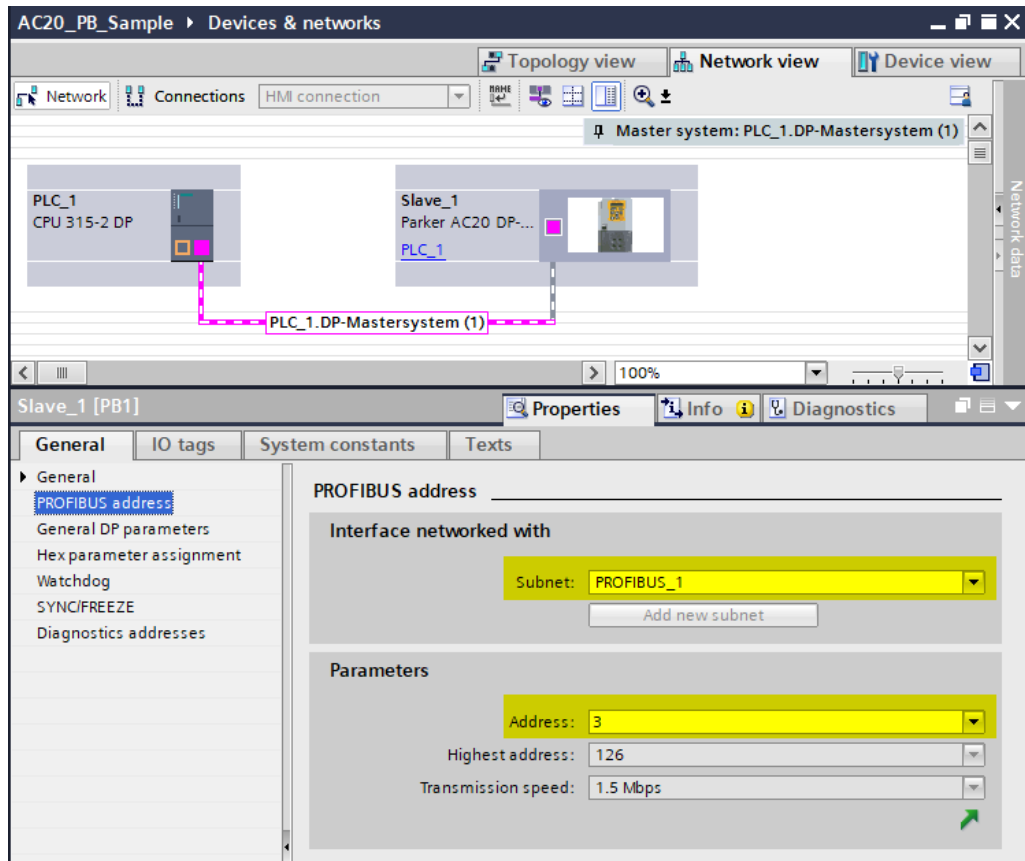

Configure Process Data Mapping

Option 1: Using AC20 Input and output mapping tables

- The parameter **2566 MASTERMAPPING** must be set to **FALSE** to prevent the PLC from overwriting the mapping.
- Through the mapping tables from the keypad, DSE Lite or Webserver, add parameter numbers into the appropriate table.

Option Comms Input Mapping		Option Comms Output Mapping	
1212	MAPPING[0]	507	MAPPING[0]
2061	MAPPING[1]	462	MAPPING[1]
584	MAPPING[2]	103	MAPPING[2]
626	MAPPING[3]	534	MAPPING[3]
497	MAPPING[4]	540	MAPPING[4]
498	MAPPING[5]	558	MAPPING[5]
0	MAPPING[6]	563	MAPPING[6]
0	MAPPING[7]	610	MAPPING[7]
0	MAPPING[8]	625	MAPPING[8]
0	MAPPING[9]	0	MAPPING[9]
0	MAPPING[10]	0	MAPPING[10]
0	MAPPING[11]	0	MAPPING[11]
0	MAPPING[12]	0	MAPPING[12]
0	MAPPING[13]	0	MAPPING[13]
0	MAPPING[14]	0	MAPPING[14]
0	MAPPING[15]	0	MAPPING[15]
0	MAPPING[16]	0	MAPPING[16]
0	MAPPING[17]	0	MAPPING[17]
0	MAPPING[18]	0	MAPPING[18]
0	MAPPING[19]	0	MAPPING[19]
0	MAPPING[20]	0	MAPPING[20]
0	MAPPING[21]	0	MAPPING[21]
0	MAPPING[22]	0	MAPPING[22]
0	MAPPING[23]	0	MAPPING[23]
0	MAPPING[24]	0	MAPPING[24]
0	MAPPING[25]	0	MAPPING[25]
0	MAPPING[26]	0	MAPPING[26]
0	MAPPING[27]	0	MAPPING[27]
0	MAPPING[28]	0	MAPPING[28]
0	MAPPING[29]	0	MAPPING[29]
0	MAPPING[30]	0	MAPPING[30]
0	MAPPING[31]	0	MAPPING[31]

Note: If the first row of a table (input mapping or Output mapping) is empty or equal to 0, the table will not be accessible and configurable from PLC.

- In Tia portal drag and drop the appropriate input and output modules from device catalogue to the AC20 slot then define the variable name.

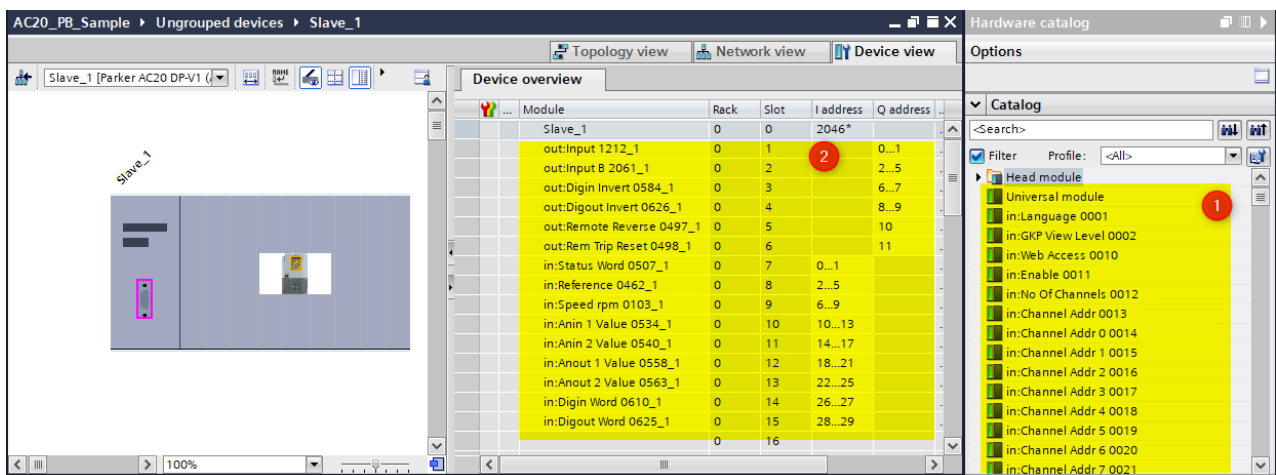

Option 2: From PLC

- The parameter **2566 MASTERMAPPING** must be set to **TRUE**.
- By selecting the slave, the input and output process data may be configured. The appropriate input and output modules may be dragged from the catalogue and dropped into the appropriate slot.
- Set the I/O address of each module then assign a name to the module variable. Each module corresponds to a drive parameter. (See step 2 of the description for Option 1)

Note: The AC20 Input/Output mapping table will be set to zero and will not have effect in this configuration.

- In the project tree click "**PLC Tags**", open "**Default tag table**", define the variable name and type then Link AC20 I/O address set below to variable.

AC20_PB_MMF ▶ PLC_1 [CPU 315-2 DP] ▶ PLC tags ▶ Default tag table [15]

Default tag table

	Name	Data type	Address	Retain	Acces...	Visibl...
1	SpeedReference	Real	%ID2		<input checked="" type="checkbox"/>	<input checked="" type="checkbox"/>
2	StatusWord	Word	%IW0		<input checked="" type="checkbox"/>	<input checked="" type="checkbox"/>
3	SpeedFeedback	Real	%ID6		<input checked="" type="checkbox"/>	<input checked="" type="checkbox"/>
4	AnalogIn1_Value	Real	%ID10		<input checked="" type="checkbox"/>	<input checked="" type="checkbox"/>
5	AnalogIn2_Value	Real	%ID14		<input checked="" type="checkbox"/>	<input checked="" type="checkbox"/>
6	AnalogOut1_Value	Real	%ID18		<input checked="" type="checkbox"/>	<input checked="" type="checkbox"/>
7	AnalogOut2_Value	Real	%ID22		<input checked="" type="checkbox"/>	<input checked="" type="checkbox"/>
8	DigitalIn_State	Word	%IW26		<input checked="" type="checkbox"/>	<input checked="" type="checkbox"/>
9	DigitalOut_State	Word	%IW28		<input checked="" type="checkbox"/>	<input checked="" type="checkbox"/>
10	ControlWord	Word	%QW0		<input checked="" type="checkbox"/>	<input checked="" type="checkbox"/>
11	SpeedSetpoint	Real	%QD2		<input checked="" type="checkbox"/>	<input checked="" type="checkbox"/>
12	Invert_DI	Word	%QW6		<input checked="" type="checkbox"/>	<input checked="" type="checkbox"/>
13	Invert_DO	Word	%QW8		<input checked="" type="checkbox"/>	<input checked="" type="checkbox"/>
14	Invert_MotRot	Bool	%Q10.0	<input type="checkbox"/>	<input checked="" type="checkbox"/>	<input checked="" type="checkbox"/>
15	TripReset	Bool	%Q11.0		<input checked="" type="checkbox"/>	<input checked="" type="checkbox"/>
16	<Add new>				<input checked="" type="checkbox"/>	<input checked="" type="checkbox"/>

Create a program to transfer data

In the example ladder code below, in Network 1 the data is read from drive to PLC and in Network 2 the PLC writes data to the drive.



- Select PLC, save the project, compile, and download to the controller.

Read / Write parameters Acyclically

The DP-V1 read / Write services can be achieved using the functions **SFB52 RDREC** and **SFB53 WRREC** with Tia portal environment.

These functions block use **INDEX 255** as required by the Call and the **ID 07FE (2046)** which is the diagnostic address found in Slot 0 of AC20 Profibus device.

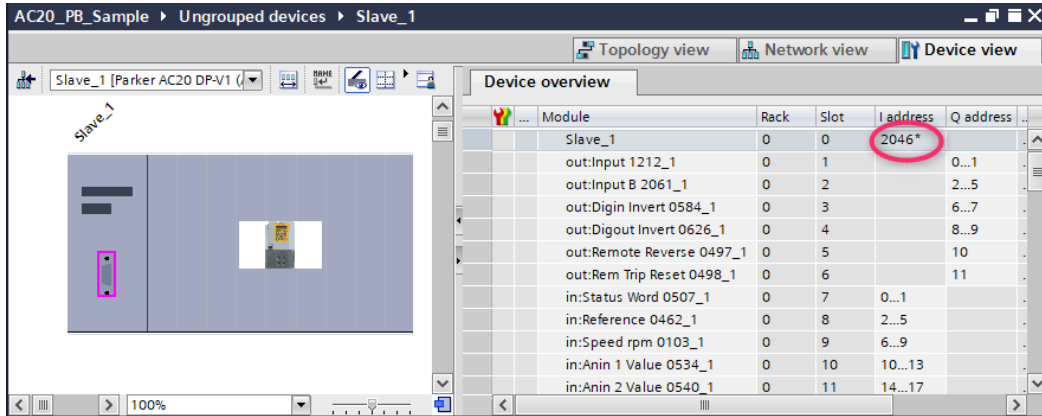

The acyclic operation takes place in two steps:

- The function block **“WRREC”** is used to send the **parameter number** during read AC20 parameter operation and to send the **parameter number and new value** during set AC20 parameter.

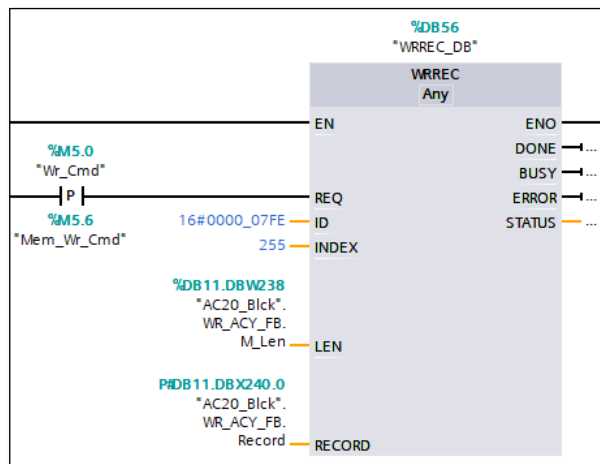

- The function block **“RDREC”** is used to **read the value** of the AC20 parameter during the read operation and to **read the status** of the command during the AC20 set parameter operation.

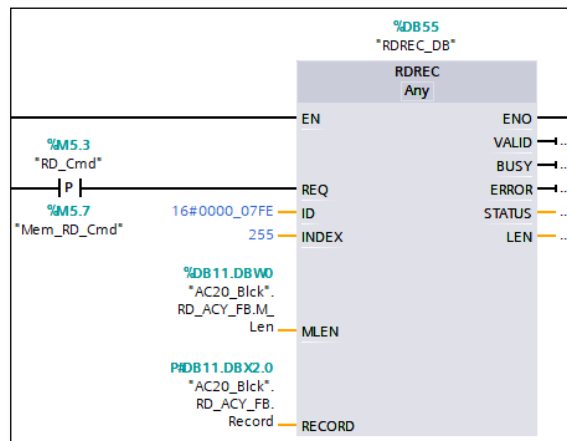

- Example: Read parameter **0056 Current Limit Out (2038h)**.
- Send parameter number with function block “WRREC”. below the value of the input length “LEN” and data Buffer “RECORD”.

	Name	Data type	Offset	Start value	Monitor value
6	WR_ACY_FB	Struct	238.0		
7	M_Len	Int	238.0	0	6
8	Record	Array[0..232] of Byte	240.0		
9	Record[0]	Byte	240.0	16#0	16#08
10	Record[1]	Byte	241.0	16#0	16#00
11	Record[2]	Byte	242.0	16#0	16#00
12	Record[3]	Byte	243.0	16#0	16#02
13	Record[4]	Byte	244.0	16#0	16#00
14	Record[5]	Byte	245.0	16#0	16#38
15	Record[6]	Byte	246.0	16#0	16#00
16	Record[7]	Byte	247.0	16#0	16#00

- Upon reception of the command in step1, the **value (150.0A=43160000h)** of the AC20 parameter is received using function block “RDREC” is shown below.

	Name	Data type	Offset	Start value	Monitor value
1	Static				
2	RD_ACY_FB	Struct	0.0		
3	M_Len	Int	0.0	0	10
4	Record	Array[0..232] of Byte	2.0		
5	Record[0]	Byte	2.0	16#0	16#08
6	Record[1]	Byte	3.0	16#0	16#00
7	Record[2]	Byte	4.0	16#0	16#00
8	Record[3]	Byte	5.0	16#0	16#02
9	Record[4]	Byte	6.0	16#0	16#00
10	Record[5]	Byte	7.0	16#0	16#38
11	Record[6]	Byte	8.0	16#0	16#43
12	Record[7]	Byte	9.0	16#0	16#16
13	Record[8]	Byte	10.0	16#0	16#00
14	Record[9]	Byte	11.0	16#0	16#00
15	Record[10]	Byte	12.0	16#0	16#00
16	Record[11]	Byte	13.0	16#0	16#00
17	Record[12]	Byte	14.0	16#0	16#00

- Example: Write parameter **0457 Motor Max Speed** (21C9h).
- Send **parameter number and value (3000.0 rpm = 453B8000h)** with function block “WRREC”. below the value of the input length “LEN” and data Buffer “RECORD”.

AC20_Block					
Name	Data type	Offset	Start value	Monitor value	
WR_ACY_FB	Struct	240.0			
M_Len	Int	242.0	0	10	
Record	Array[0..232] of Byte	244.0			
Record[0]	Byte	244.0	16#0	16#08	<div style="border: 1px solid red; border-radius: 15px; padding: 5px; display: inline-block; background-color: red; color: white; font-weight: bold;">Parameter number</div> <div style="border: 1px solid red; border-radius: 15px; padding: 5px; display: inline-block; background-color: red; color: white; font-weight: bold;">Parameter New Value</div>
Record[1]	Byte	245.0	16#0	16#00	
Record[2]	Byte	246.0	16#0	16#00	
Record[3]	Byte	247.0	16#0	16#01	
Record[4]	Byte	248.0	16#0	16#01	
Record[5]	Byte	249.0	16#0	16#C9	
Record[6]	Byte	250.0	16#0	16#45	
Record[7]	Byte	251.0	16#0	16#3B	
Record[8]	Byte	252.0	16#0	16#80	
Record[9]	Byte	253.0	16#0	16#00	
Record[10]	Byte	254.0	16#0	16#00	

- Upon receipt of the command in step 1, the **Command Status** is received using function block “RDREC” is shown below.

AC20_Block					
Name	Data type	Offset	Start value	Monitor value	
Static					
RD_ACY_FB	Struct	0.0			
M_Len	Int	2.0	0	6	
Record	Array[0..232] of Byte	4.0			
Record[0]	Byte	4.0	16#0	16#08	<div style="border: 1px solid red; border-radius: 15px; padding: 5px; display: inline-block; background-color: red; color: white; font-weight: bold;">Parameter number</div> <div style="border: 1px solid red; border-radius: 15px; padding: 5px; display: inline-block; background-color: red; color: white; font-weight: bold;">Status Set Command</div>
Record[1]	Byte	5.0	16#0	16#00	
Record[2]	Byte	6.0	16#0	16#00	
Record[3]	Byte	7.0	16#0	16#01	
Record[4]	Byte	8.0	16#0	16#01	
Record[5]	Byte	9.0	16#0	16#C9	
Record[6]	Byte	10.0	16#0	16#00	
Record[7]	Byte	11.0	16#0	16#00	

The following relevant read / write error codes may be returned:

Error code 1	Error code 2	Error Type	Description
0xB0	0x04	Invalid index	Parameter number out of range
0xB1	0X0A	Write error length	Too much data
0xB1	0X0B	Write error length	Not enough data
0xB6	0X08	Access denied	Parameter not writable
0xB6	0X09	Access denied	Parameter not readable
0xB7	0X0C	Invalid range	Value out of range

10 Lost Communication Trip

Supervised Parameter:

The **0777 Comms Supervised** parameter indicates that the Profibus network participation is supervised by another Profibus device.

The Supervised parameter value is set to TRUE when either:

- The Parameterization and configuration data have been accepted (connection established)
- An MS (Machine State) connection is open

The Supervised parameter will subsequently change to FALSE if the connection is closed or the Profibus watchdog (if enabled) has timed out.

Comms Break Trip

The drive will trip when there is a loss of communications between the master and the drive.

A COMMS BREAK trip will occur if the **0777 Comms Supervised** parameter transitions from TRUE to FALSE and the drive is in the operational state.

The trip may be disabled by clearing the respective bit in the parameter **0870 Enable Trips Lo**. The parameter Enable Trip Lo is a 32-bit word, the bit number 27 is used to disable or to enable the trip.

Comms state

The parameter **0774 Comms State** indicates 'PROCESS_ACTIVE' when the Profibus communication is active. The table below describes how the comms state relates to the Profibus network:

Comms State	Comments
WAIT_PROCESS	No MS0 connection DP state = Power-On/WaitPrm/WaitCfg MS2 connection may be open
ERROR	-
PROCESS_ACTIVE	Master Mode = Operate DP State = DataExchange MS0 connection established MS2 connection may be open
IDLE	Master Mode = Clear DP State = DataExchange MS0 connection established MS2 connection may be open
EXCEPTION	S0, MS1 and MS2 connections will be closed. The module will enter this state in the following cases: <ul style="list-style-type: none"> • Invalid Device Address and "SSA Enabled" = FALSE • Size of 'Configuration Data' attribute is larger than the size of the Configuration Data Buffer. • Major Unrecoverable event created in Diagnostic Object. • Configuration Data does not match the mapped Process Data. • Application watchdog expires.

Note:

-MS0 is a communication protocol for cyclic.

-MS1 and MS2 communications are used for acyclic control of parameters

11 Diagnostic Event

Configuration problems can often be identified by looking at the Operation Mode and Status LEDs and from the Profibus State and Comms Diagnostic **0775 parameters**. Under normal operating conditions the parameter Comms Diagnostic should indicate OK. Other values are summarized in the Diagnostic Parameters section.

Hardware Mismatch

Diagnostic = HARDWARE MISMATCH:
The required option does not match the actual fitted option.
No option is fitted but one is required.

Invalid Configuration

Diagnostic = INVALID CONFIGURATION:
Invalid read or write process data mapping
Invalid communication settings

Diagnostic = MAPPING FAILED:

Attempting to map a parameter that does not exist.
Attempting to map a configuration parameter.
Attempting to map a string parameter.
Attempting to map a read-only parameter to the read process data.

Other Diagnostics

Diagnostic = EXCEPTION :
Module has gone into an unrecoverable exception state

Diagnostic = UNSUPPORTED OPTION:
The fitted option is not supported by the drive

Diagnostic = NOT RESPONDING:
no initial response from the option

PLC Indications

Flashing Bus Fault (BF) LED on the PLC:
A module in the hardware configuration (HW Config) does not match the physical module or that the module is not connected to the network.

APPENDIX A: Data types

The relationship between AC20 parameter and CANopen data type is given in the table below.

AC20 Parameter		Profibus	
Data Type	Description	Data Type	Bytes
BOOL	Boolean	BOOL	1
SINT	Short integer	SINT	1
INT	Integer	INT	2
DINT	Double integer	DINT	4
USINT	Unsigned short integer	USINT	1
UINT	Unsigned integer	UINT	2
UDINT	Unsigned double integer	UDINT	4
REAL	Floating point	FLOAT	4
TIME	Duration	UDINT	4
DATE	Date	UDINT	4
TIME_OF_DAY	Time of day	UDINT	4
DATE_AND_TIME	Date and time of day	UDINT	4
STRING	String	SHORT_STRING**	<i>n</i>
BYTE	Bit string length 8	USINT	1
WORD	Bit string length 16	UINT	2
DWORD	Bit string length 32	UDINT	4

** SHORT_STRING consists of a single-byte length field followed by the actual character data

Arrays

Some parameters have multiple elements and are classified as parameter arrays. A parameter array has a parameter number that accesses the *whole* of the array. It also has parameter numbers that represent each *element* of the array.

Array Example: A parameter array called **VHZ_USER_FREQ** has 11 elements.

Parameter Number	Parameter - VHZ_USER_FREQ
0145	whole array
0146	index 0
0147	index 1
...	...
0157	index 10

If the parameter number of the whole array is 0145, then the parameter number of the element index 0 of the array will be 0146, the parameter number of the element index 01 will be 0147, etc.

String

String parameters may be accessed via its parameter number. This is in the format of a SHORT_STRING. String arrays may not be accessed as a whole array but may be accessed via each element. Each element has its own parameter number.

APPENDIX B: Parameters

Function Block Inputs

Parameter Name	No.	Default Value	Range	Units	Type	Writable
COMMS REQUIRED	691	1: None	0: Unknown 1: None 2: CANopen 3: EtherCAT 4: Ethernet IP 5: Modbus RTU 6: Profibus 7: Profinet		ENUM	CONFIG
Communications option required.						
ADDR ASSIGNMENT	758	0: External	0: External 1: Fixed 2: DHCP		ENUM	CONFIG
Method for assigning the IP address.						
SET IP ADDRESS	759	0			ADDR	CONFIG
Ethernet option IP address						
SET SUBNET MASK	760	0			ADDR	CONFIG
Ethernet option subnet mask.						
SET GATEWAY ADDR	761	0			ADDR	CONFIG
Ethernet option gateway address.						
ACCESS	762	31: 31	0: IP Config Enable 1: Web Enable 2: Web Parameters Enable 3: FTP Enable 4: FTP Admin Mode		WORD	CONFIG
Ethernet access using comms option (bitwise)						
NODE ADDRESS	763	0			USINT	CONFIG
Communications node address.						
CANOPEN BAUD	764	9: Auto	0: 10 kbps 1: 20 kbps 2: 50 kbps 3: 100 kbps 4: 125 kbps 5: 250 kbps 6: 500 kbps 7: 800 kbps 8: 1000 kbps 9: Auto 10: Lss		ENUM	CONFIG
Required baud Rate for CANopen.						
MODBUS BAUD RATE	765	4: 19200 BPS	0: 1200 bps 1: 2400 bps 2: 4800 bps 3: 9600 bps 4: 19200 bps 5: 38400 bps 6: 57600 bps 7: 76800 bps 8: 115200 bps		ENUM	CONFIG
Required baud Rate for Modbus RTU						
PARITY	766	0: Even 1 Stop	0: Even 1 Stop 1: Odd 1 Stop 2: None 2 Stop 3: None 1 Stop		ENUM	CONFIG
Modbus parity and stop bits						
HIGH WORD FIRST	767	FALSE			BOOL	CONFIG
For 32-bit values high word comes first if set to TRUE.						
ACTIVE TIMEOUT	768	0	0 to 65		TIME	CONFIG
Process active timeout period.						

Parameter Name	No.	Default Value	Range	Units	Type	Writable
MASTERMAPPING	2566	TRUE			BOOL	CONFIG
Switch to choose how the PROFINet, EtherCAT, PROFibus and CanOpen PDO mapping is defined: If TRUE the bus master sets/configures the PDO mapping. The drive mapping parameters 692...757 are cleared (set to zero) and made invisible (GKP and website) as this the required condition. If FALSE the mapping parameters 692...757 are visible (Keypad and webserver) can be used to define the PDO mapping from drive side (which the bus master then can upload). The switch is considered during drive startup (stopped -> operational transition).						

Function Block Outputs

Parameter Name	No.	Default Value	Range	Units	Type	Writable
COMMS FITTED	769	0: Unknown	0: Unknown 1: None 2: CANopen 3: EtherCAT 4: Ethernet IP 5: Modbus RTU 6: Profibus 7: Profinet		ENUM	NOT
Communications option fitted.						
COMMS VERSION[0]	770	0			USINT	NOT
Firmware version of the comms module.						
COMMS VERSION[1]	770	0			USINT	NOT
Firmware version of the comms module.						
COMMS SERIAL NUM	773	0			DWORD	NOT
Serial number of the comms module.						
COMMS STATE	774	8: None	0: Setup 1: NW Init 2: Wait Process 3: Idle 4: Process Active 5: Error 6: Reserved 7: Exception 8: None		ENUM	NOT
State of the option comms.						
DIAGNOSTIC	775	0: Ok	0: Ok 1: Hardware Mismatch 2: Invalid Configuration 3: Mapping Failed 4: Exception 5: Unsupported Option 6: Not Responding		ENUM	NOT
Diagnostic for the comms option.						
EXCEPTION CODE	776	0			WORD	NOT
Diagnostic code on option entering exception state. The MSB is the exception code and the LSB is the exception info.						
COMMS SUPERVISED	777	FALSE			BOOL	NOT
Indicates a master has made a connection to the device.						
MAPPING CHANGED	778	FALSE			BOOL	NOT
The PLC has changed the process data mapping from that set by the drive.						
STATION NAME	779				STRING	NOT
Current PROFINET station name.						
IP ADDRESS	787	0			ADDR	NOT
Current Ethernet option IP address.						
SUBNET MASK	788	0			ADDR	NOT
Current Ethernet option subnet mask.						
GATEWAY ADDRESS	789	0			ADDR	NOT
Current Ethernet option gateway address.						

Parameter Name	No.	Default Value	Range	Units	Type	Writable
ACTUAL BAUD RATE	790	0: 10 kbps	0: 10 kbps 1: 20 kbps 2: 50 kbps 3: 100 kbps 4: 125 kbps 5: 250 kbps 6: 500 kbps 7: 800 kbps 8: 1000 kbps 9: Auto 10: lss		ENUM	NOT
Actual CANopen baud rate.						

APPENDIX C: DSE Lite Quick Start Guide

Follow the steps below to configure the AC20 via DSE Lite PC-Tool.

The block diagram of the AC20 may be accessed through the onboard webserver or DSE Lite.

DSE Lite is recommended.

The IP address of the AC20 is in the range 169.254.xx.xx by default. Therefore, the user's PC network adapter must be configured to this range as shown below (IPv4 is used for communication).

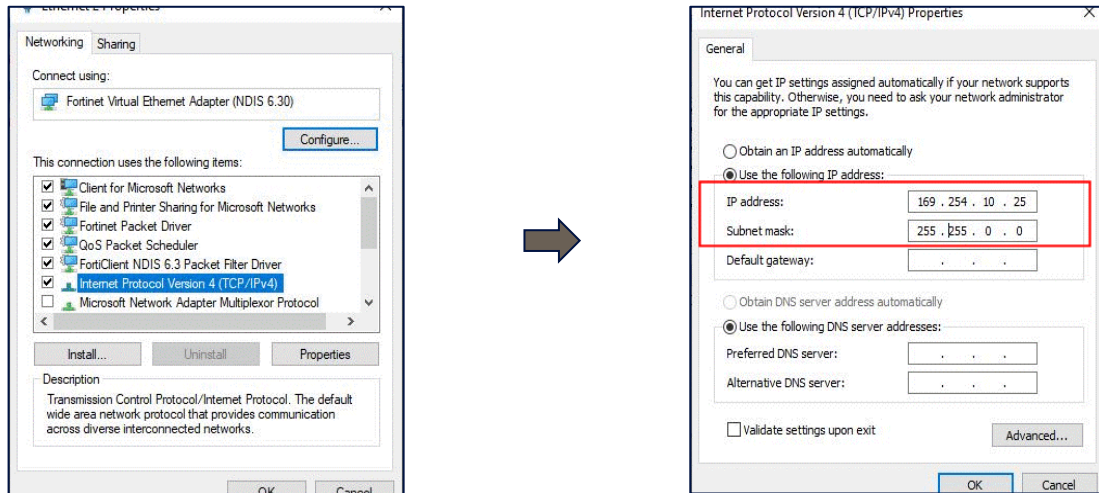

Alternatively, the IP address of the drive may be changed to suit the settings of the PC network adapter. The IP address of the drive can be configured using the DCT function, accessible from within DSE Lite by selecting Command -> Install AC15/AC20 Firmware.

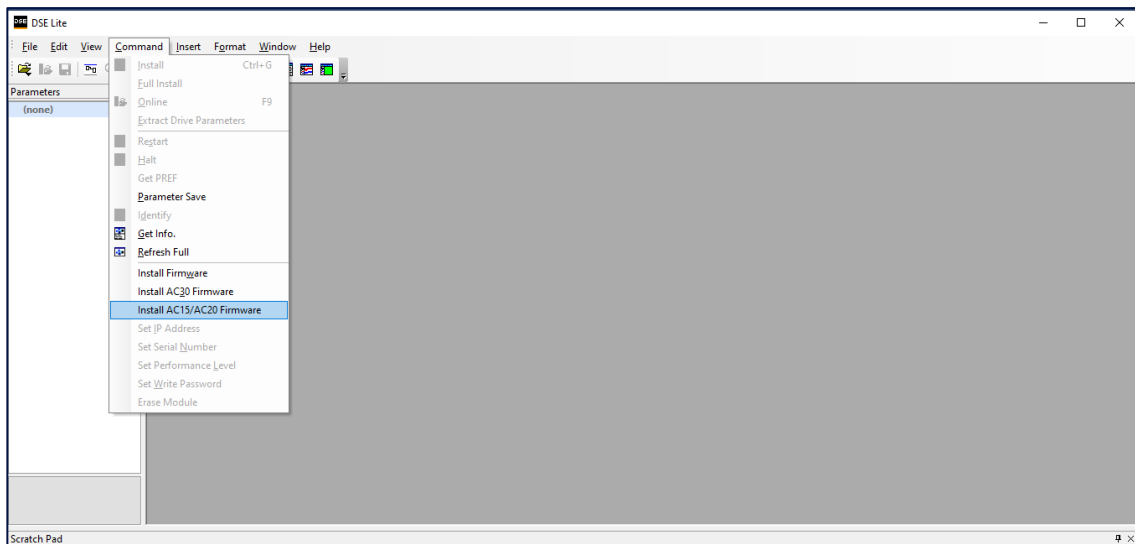

Once the network scan is completed, then the drive settings can be edited.

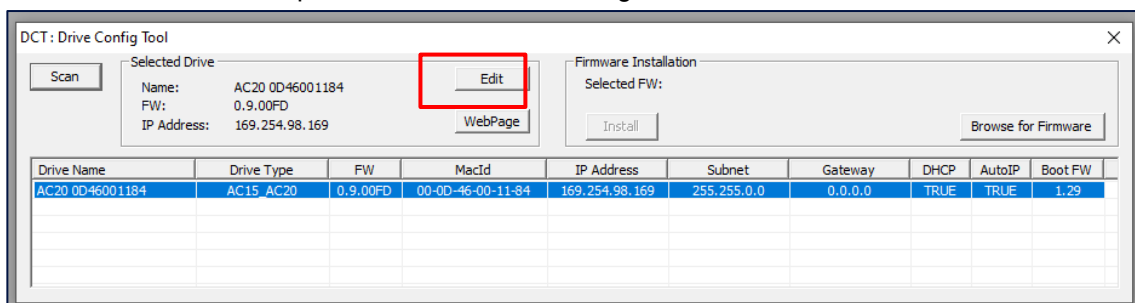

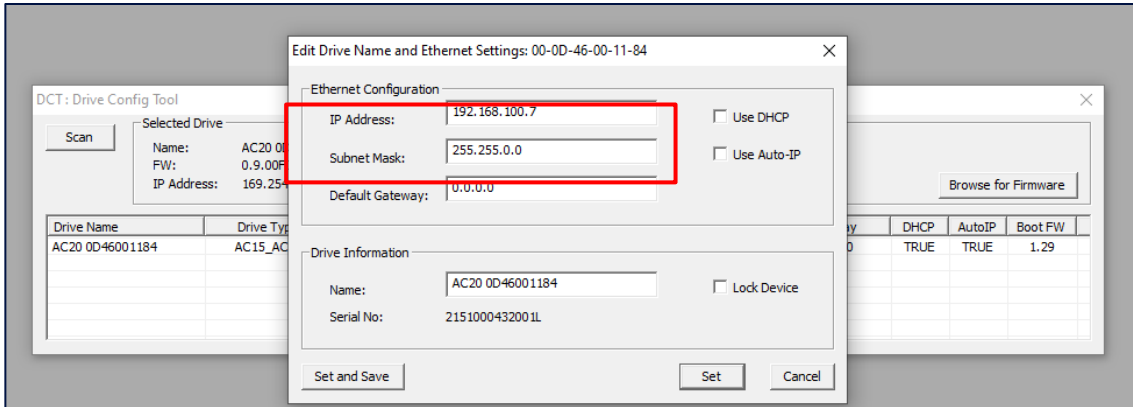

If the drive is not found by DSE lite, or a new drive is connected to the Ethernet port, a network scan must be performed again, as blow.

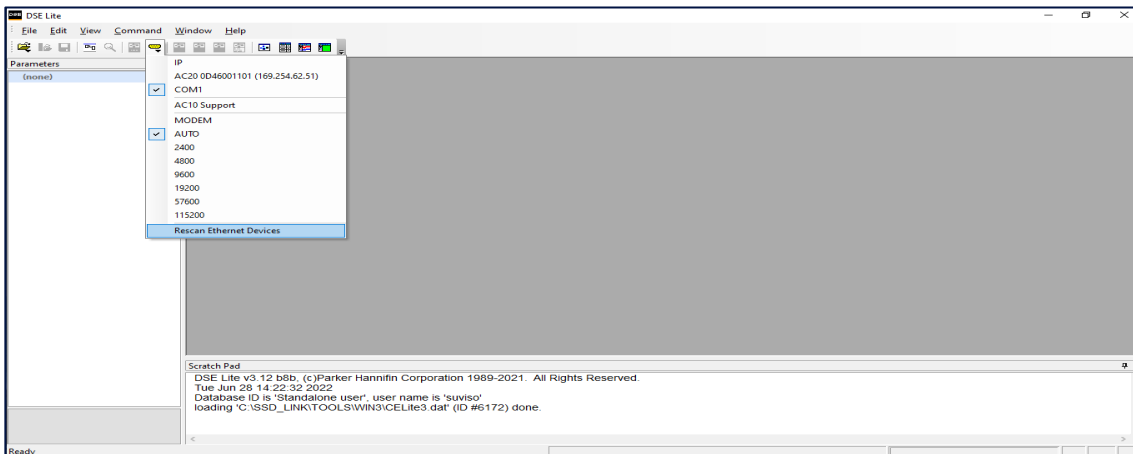

Once the network scan has been performed, any AC20 connected to the network will appear and DSE lite can connect to the drive.

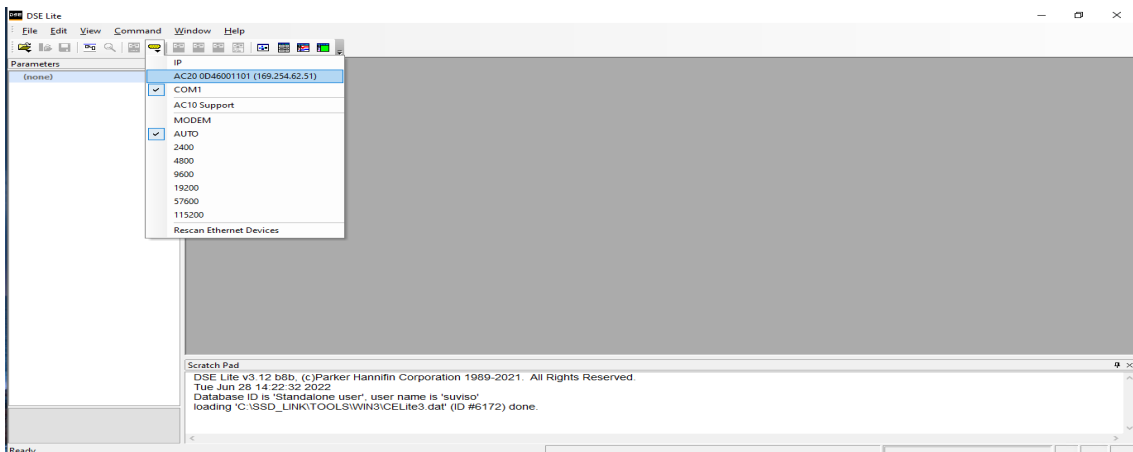

When connected to a drive, this is shown in the scratch pad.

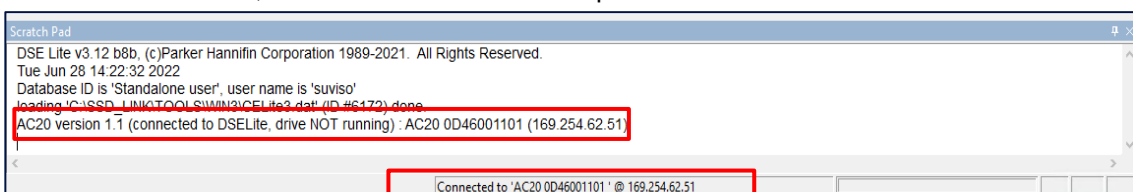



EMAC s.r.o.
Kasarenska 2404/26
911 05 Trencin
SLOVAKIA

Parker certified distributor
☎ +421 32 3810 232
✉ info@emac.sk
🌐 www.emac.sk